

# Parker Balston® Models N2-14, N2-22, N2-35, N2-14A, N2-22A, and N2-35A Nitrogen Generators

Figure 1 Overall Dimensions

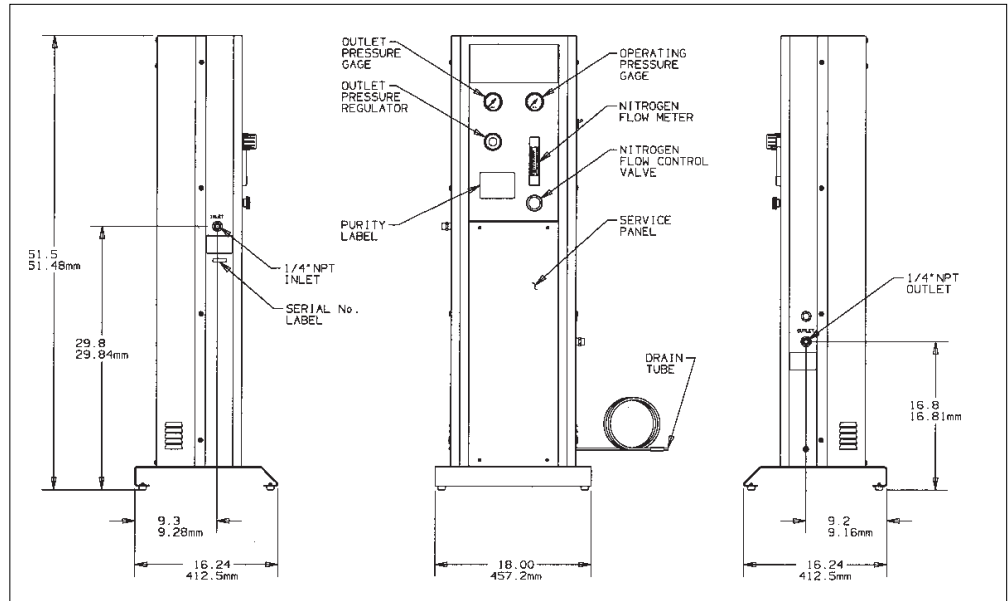

Models N2-14, N2-22, and N2-35

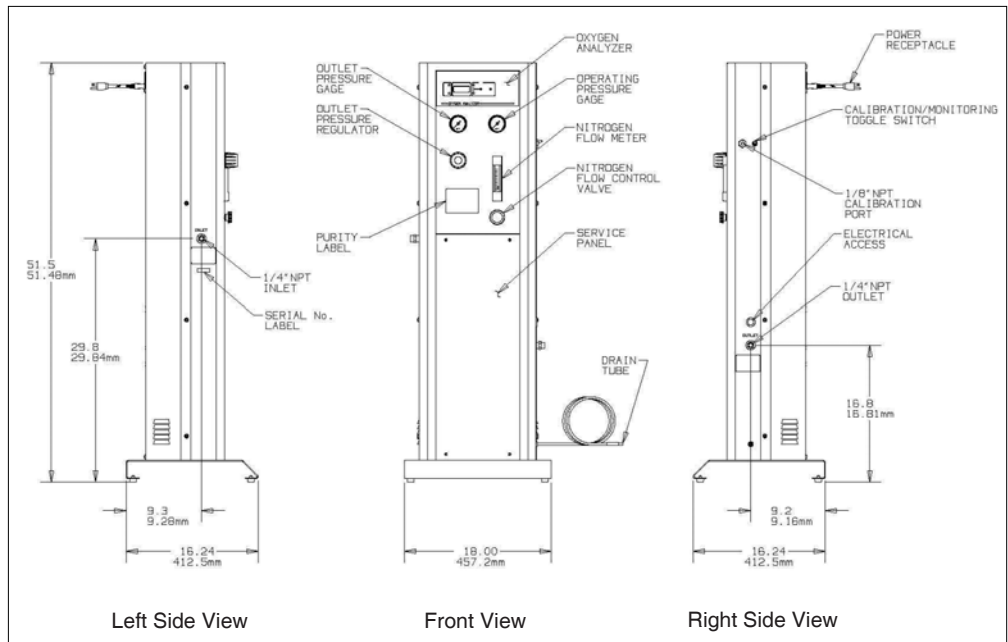

Models N2-14A, N2-22A, and N2-35A

These instructions must be thoroughly read and understood before installing and operating this product. Failure to operate this product in accordance with these instructions could present a safety hazard to the user and will void the safety certification of this product. Modification of the unit will result in voiding the warranty. If you have any questions or concerns, please call the Technical Services Department at 800-343-4048, 8AM to 5PM Eastern Time (North America only). For other locations, please contact your local representative. Email to: [BalstonTechSupport@Parker.com](mailto:BalstonTechSupport@Parker.com).

**N2-14, N2-22, N2-35, N2-14A, N2-22A, N2-35A Parker Balston Nitrogen Generators**

---

**General Description**

The Parker Balston Nitrogen Generator is a completely engineered system which will transform a compressed air supply into 95% to 99.5% purity compressed nitrogen. The system is based on state-of-the-art membrane technology. Compressed air flows through the hollow fiber membrane module and is separated into a concentrated nitrogen output stream and an oxygen enriched permeate stream. The compressed nitrogen is filtered and delivered to the process or equipment downstream. The permeate is vented to the atmosphere.

The Parker Balston N2-14A, N2-22A, and N2-35A Nitrogen Generators have integrated oxygen analyzers and have been certified to IEC 1010 Standards (CSA 22.2 No. 1010.1-92). These generators bear the CSA safety marking on the product label.

**Engineered System**

The Parker Balston Nitrogen Generators include all the components required to convert compressed air into high purity nitrogen and monitor the purity of that nitrogen (Models N2-14A, N2-22A, and N2-35A only).

The flow schematics in Figure 2 show all of the major components of the systems. Each system can be broken down into five primary functional groups: prefiltration, air separation, flow controls, final filtration, and nitrogen purity monitoring (Models N2-14A, N2-22A, and N2-35A only).

**Description****Prefiltration**

Two coalescing prefilters and one activated carbon scrubber are incorporated into the Parker Balston Nitrogen Generator to protect the membrane module from contamination. These filters are located behind the filtration access panel. The coalescing filters remove liquids and particulate matter from the incoming air supply and are equipped with float drains which automatically drain any liquids which accumulate inside the filter housing. The drains are connected to 1/4" O.D. plastic tubing which discharges to atmosphere at the back of the nitrogen generator (see Figure 1). The activated carbon filter removes hydrocarbons which may be detrimental to the membrane fibers.

**Air Separation**

Air separation takes place in the membrane module. The module consists of bundles of hollow fiber membranes. As the air passes through these hollow fibers, oxygen and water molecules pass through the membrane wall at a higher rate than nitrogen molecules. This results in a high purity, dry nitrogen gas stream exiting the membrane module. The oxygen enriched permeate stream exits the membrane module through ports on the side of the module at a very low pressure.

**Final Filtration**

The final filter is a .01 micron (absolute) membrane filter. The final membrane filter will assure the user a clean, commercially sterile supply of high purity nitrogen.

**Controls**

The controls in the Parker Balston Nitrogen Generator consist of an operating pressure gauge, a flowmeter and flow control valve, and an outlet pressure regulator and gauge (see Figure 1). Proper use of these controls will assure the user of a 95% to 99.5% nitrogen outlet stream, depending on operating pressure and flow rate. The pressure gauges, which are mounted on the front panel, measure operating pressure and outlet pressure. The flowmeter measures the flow rate of nitrogen exiting the membrane module. The scale on this flowmeter is dimensionless because the operating pressure can range from 60 psig to 145 psig (4 barg to 10 barg). The Nitrogen Purity Label on the control panel is used to convert the dimensionless flowmeter reading to SLPM (standard liters per minute), based on operating pressure and required purity. The flow control valve is used to set the flow rate through the system. The outlet pressure regulator allows the user to set the pressure of the emergent nitrogen gas stream.

**N2-14, N2-22, N2-35, N2-14A, N2-22A, N2-35A Parker Balston Nitrogen Generators**

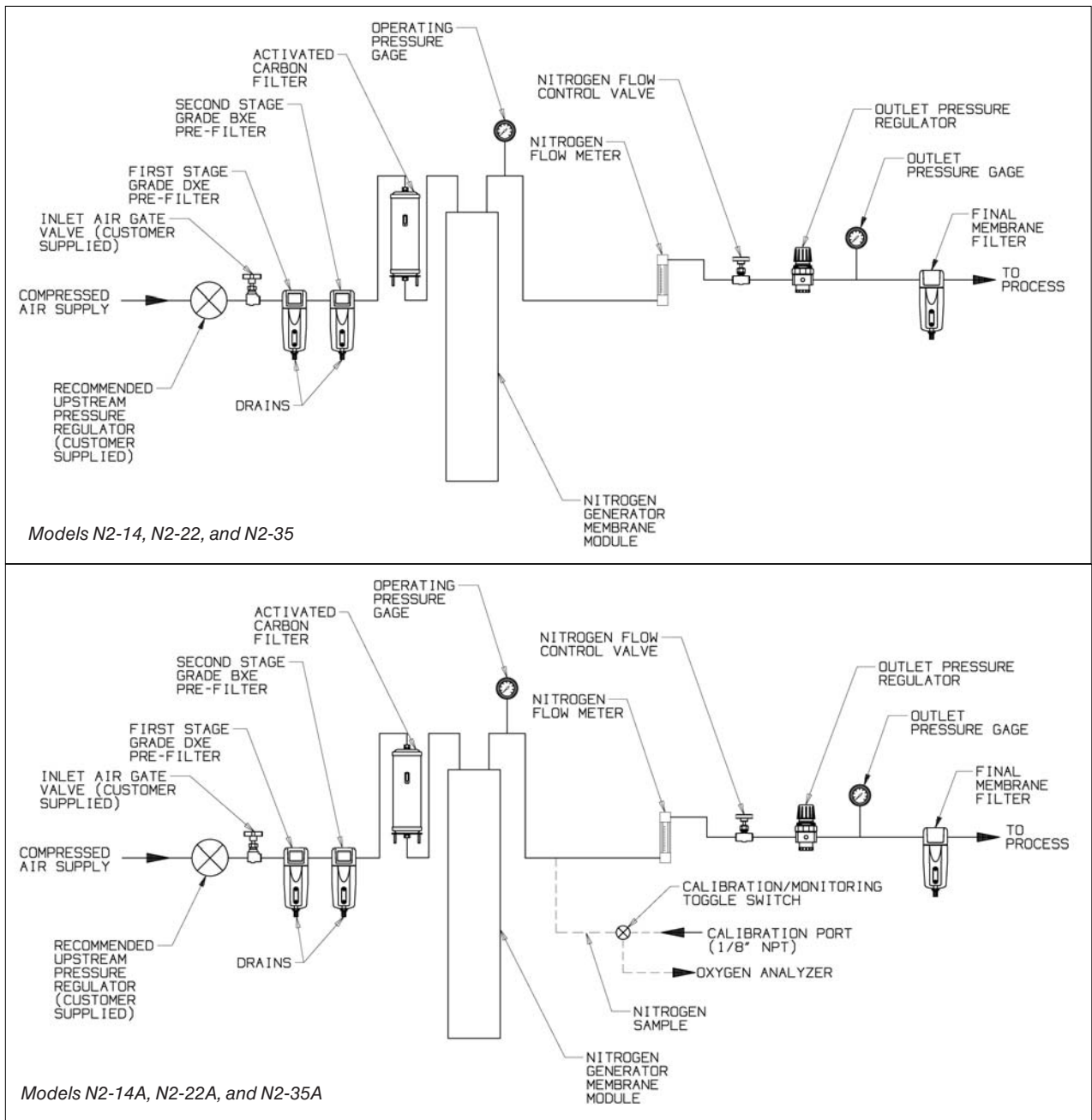

Figure 2 - Flow Schematic

**Oxygen Monitoring**  
(Models N2-14A, N2-22A and N2-35A only)



**Note:** In hazardous applications where the oxygen content is critical (i.e., blanketing explosive chemicals or packaging food for extended shelf life), an oxygen monitor and/or trace oxygen analyzer should be used in conjunction with safety interlocks and/or alarm systems to assure proper nitrogen purity levels at all times.

An oxygen analyzer has been incorporated into the design of the N2-14A, N2-22A, and N2-35A Nitrogen Generators to monitor the oxygen content of the nitrogen process stream. The sensing device in the oxygen analyzer is a galvanic cell. The analyzer has an internal temperature compensation circuit to provide accurate readings within a specified temperature range.

The oxygen analyzer has all the controls necessary to assure safe and accurate monitoring of the oxygen concentration in a process stream. The analyzer is equipped with the following controls and features (see Figure 3).

**N2-14, N2-22, N2-35, N2-14A, N2-22A, N2-35A Parker Balston Nitrogen Generators**

**Alarm Controls** - The alarm controls are located on the right side of the oxygen analyzer panel. The switch on the far right side of the front panel enables the audible alarm. When enabled, the audible alarm will sound if the oxygen concentration in the process stream exceeds the alarm set points set by the user. The alarm set switch is located to the left of the audible alarm control switch. The two potentiometers used to set alarm trigger points are located to the left of the alarm set switch. The LEDs above and below the alarm set switch give a visual indication of oxygen concentrations beyond the specified range.

**Oxygen Concentration Display** - The oxygen concentration LED display shows oxygen concentration, in percent, to the nearest 0.1%.

**Calibration Controls** - The calibration controls are located to the left of the oxygen concentration display. The zero potentiometer is used to zero the instrument when a zero gas (containing no oxygen) is introduced. The span potentiometer is used to set the analyzer reading to the specified concentration of oxygen in the span gas. The inlet port to the generator for the calibration gas is 1/8" NPT and is located on the back of the generator, as shown in Figure 1. The switch located below the calibration port (see Figure 1) is toggled up for calibration and down for nitrogen purity monitoring.

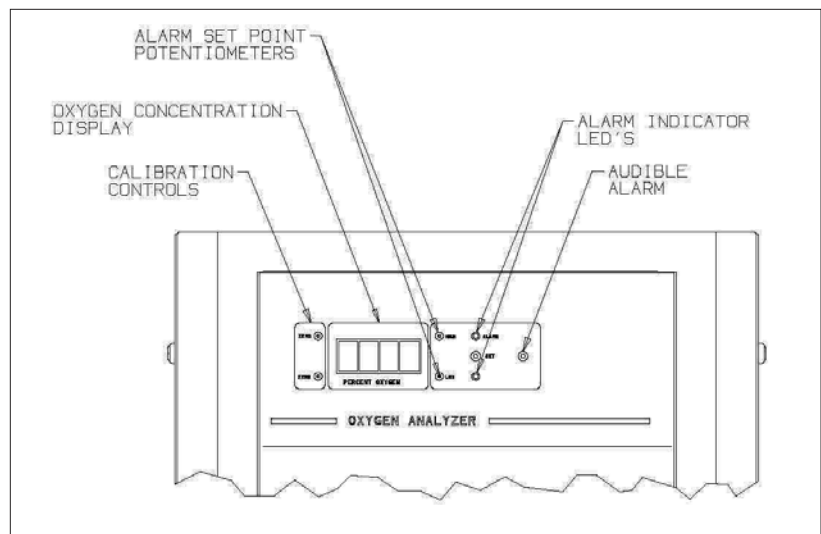

Figure 3 - Front Panel Controls

## Installation

### Moving

The Parker Balston Nitrogen Generator is shipped on a wooden skid. The generator may be removed from the skid when it arrives at the customer location, or it may be transported to its final destination while skidded. If the generator is removed from the skid, use a two-wheeled dolly. If the generator remains skidded while being moved, use a device approved for transporting skidded products.

### General



The Parker Balston® Nitrogen Generator is a free-standing unit. **Do not suspend the nitrogen generator from a wall or ceiling. Its considerable weight and size could pose a falling hazard.**

The inlet and outlet ports on the generator are 1/4" female NPT. A 1/4" male connector rated for 145 psig (10 barg) should be used to connect to the nitrogen generator. (**Note:** Parker recommends that the inlet piping and fittings in the compressed air delivery system be of the same size or larger than the inlet fittings on the Nitrogen Generator. This will help ensure an adequate supply of air to the generator.) Consult Figure 4 for the location of the following recommended external controls.



**Shutoff Valve** - A shutoff valve should be installed directly upstream from the nitrogen generator to facilitate routine maintenance and troubleshooting procedures. **The valve used should always be opened slowly.** Opening a valve quickly will pressurize the membrane too rapidly and may cause membrane rupture. Membrane failures resulting from improper valve installation will not be covered under warranty.

**N2-14, N2-22, N2-35, N2-14A, N2-22A, N2-35A Parker Balston Nitrogen Generators**

**Pressure Regulator** - A pressure regulator should be installed directly upstream from the nitrogen generator to set and maintain the inlet air pressure. Maintaining a constant inlet air pressure is critical to the performance of the system. The regulator should be properly sized to prevent a pressure drop at the generator inlet.

**Flow Controller** - If the application requires nitrogen at pressures higher than 10 psig (0.7 barg), install a flow controller downstream from the nitrogen generator, close to the point of use (see Adjustment Procedure in Operation section).

**Hydrocarbon Scrubber** - The installation of the Parker Balston Hydrocarbon Scrubber P/N 72-905 on the outlet of the nitrogen generator (see Figure 4) is recommended for applications requiring very high purity detection levels. The life of the Hydrocarbon Scrubber depends upon the flow rate of the generator. The lower the flow the longer the scrubber will last.

**Location**

The generator should be located indoors, protected from severe weather conditions, and free from excessive ambient dust or dirt. **Do not install the generator outdoors.** The ambient temperature of the air surrounding the generator must be between 60°F and 95°F (15°C and 35°C). The environment surrounding the nitrogen generator should also be adequately ventilated; allow a minimum of 6" (15 cm) clearance on all sides of the generator.



**The generator creates a 30% to 40% oxygen permeate stream which may pose a flammability problem in an oxygen sensitive environment.**

**Consult Figures 4 and 5 for the recommended location of the following external controls.**

**Utilities**

**Compressed Air** - The Parker Balston Nitrogen Generator requires a source of clean, dry compressed air between 60 psig and 145 psig for operation. The incoming air should also be between 60°F and 95°F (15°C and 35°C), and relatively free of water, compressor oil, hydrocarbons, and particulate matter. An oil content of <0.01 mg/m<sup>3</sup> is recommended. The compressed air dewpoint is recommended to be less than or equal to 40°F (5°C) at 145 psi. The compressed air consumption varies with inlet pressure and nitrogen purity. Consult chart in System Specification Section to ensure an adequate supply of compressed air is available for the generator.

**Power** - A 120 VAC or 240 VAC, 50/60 Hz power supply is required to energize the oxygen analyzer. (**Note:** Main supply line voltage must be within 10% of the nominal rated voltage for the generator.) The power receptacle is located on the back of the unit (see Figure 1).

The Parker Balston Nitrogen Generator is preset at the factory for operation at 120 VAC. The voltage setting for the generator is shown through a small window on the power entry module on the back of the generator. **Check the voltage selector setting prior to energizing the generator.** The selector setting should match the voltage of the local power supply and the product label.

If the voltage selector displays an input power voltage different from the local power supply, it may be changed using only a small screwdriver. (**Note: The "NA" version of the generator is designed to operate at 120 VAC only.**) First, use the screwdriver to release the cover of the power entry module on the back of the generator (see Figure 1). Next, rotate the voltage selector until the desired input voltage is displayed in the window. Finally, replace the power entry module cover.

**Drain Lines** - The drain line from the first two stages of prefiltration will consist of water and compressor oil and should be piped away to an appropriate disposal container.

**N2-14, N2-22, N2-35, N2-14A, N2-22A, N2-35A Parker Balston Nitrogen Generators**

**Receiving Tank Installations**

In many applications, the flow requirements for nitrogen can fluctuate with time. As noted earlier, if the flow rate of the nitrogen stream varies, the purity level of the nitrogen also varies; therefore, it is important to keep the nitrogen flow as constant as possible. A receiving tank can be installed between the nitrogen generator and the process to accommodate fluctuations in nitrogen demand and maintain nitrogen purity.

If a receiving tank is to be used, a back pressure regulator and a check valve should be installed between the Parker Balston Nitrogen Generator and the receiver tank (see Figure 4). The Parker Balston 72-460-V883 Back Pressure Controller contains both of these components and may be ordered as an accessory for the nitrogen generator. The adjustable back pressure regulator, when set to the appropriate pressure, will maintain a constant pressure drop across the flow control valve. By controlling the pressure drop across the flow control valve, the nitrogen flow will be kept constant and the variability in purity of the nitrogen process stream will be minimized. The check valve, when installed properly, will prevent any flow of nitrogen from the receiver upstream toward the generator, providing a more effective means of storing the nitrogen.

Figure 4 - Recommended Installation, all models

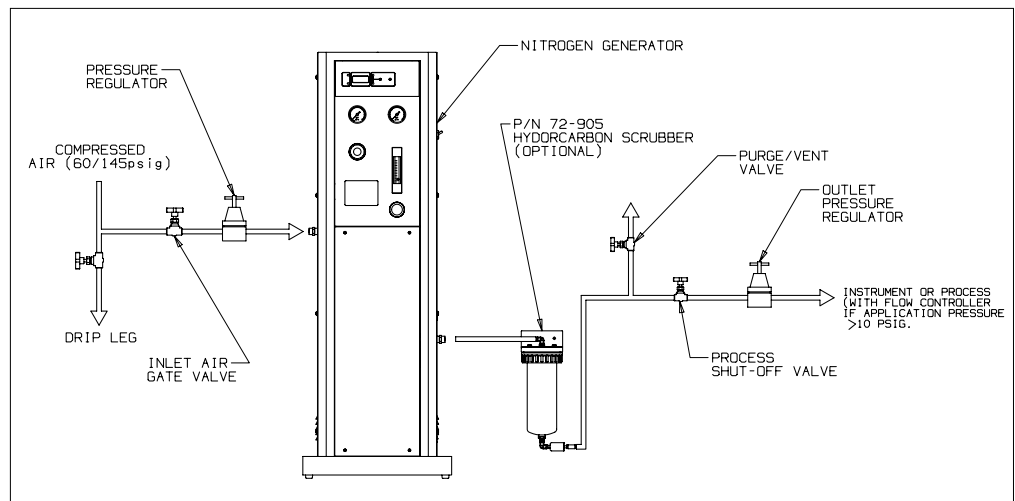
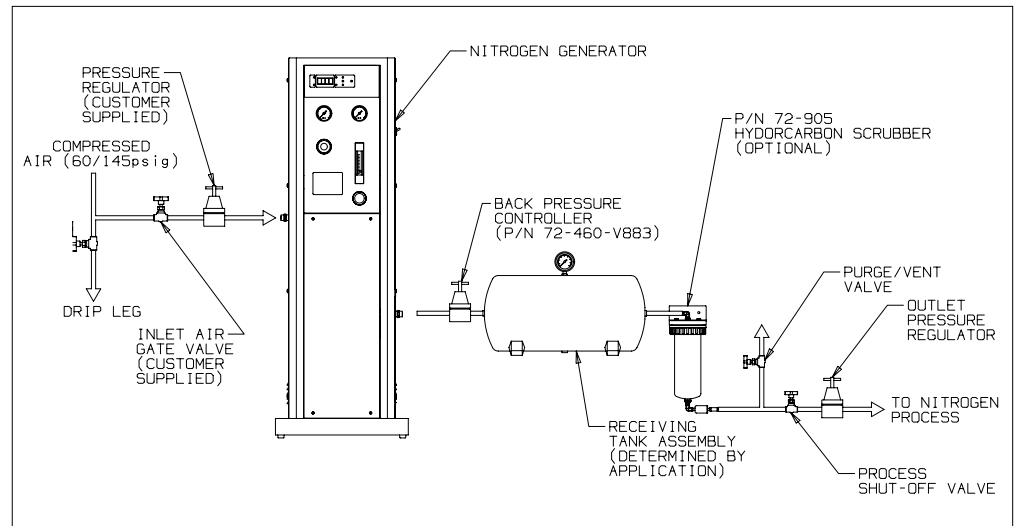

Figure 5 - Recommended Installation with a Receiving Tank, All models



**N2-14, N2-22, N2-35, N2-14A, N2-22A, N2-35A Parker Balston Nitrogen Generators****Installation: Oxygen Monitor (Models N2-14A, N2-22A and N2-35A)****Galvanic Cell Installation**

The galvanic cell is **not** installed into the generator prior to shipment. It is shipped in the bag which contains the documentation for the product. The only tools needed to install the sensor are a small flat head or Phillips screwdriver and wire strippers. The procedure for installing the sensor is outlined below and takes approximately 10 minutes.

**Disconnect generator from power supply before installing galvanic cell sensor.**

- 1 Remove filter access panel and sensor cover to expose galvanic cell holder (see Figure 6).
- 2 Strip sensor connecting wires to 1/4" to 3/8" (6mm to 9mm) using wire strippers.
- 3 Connect the stripped wires to the screw connections provided being sure to maintain the proper polarity (black -, red +).
- 4 Replace filter access panel.

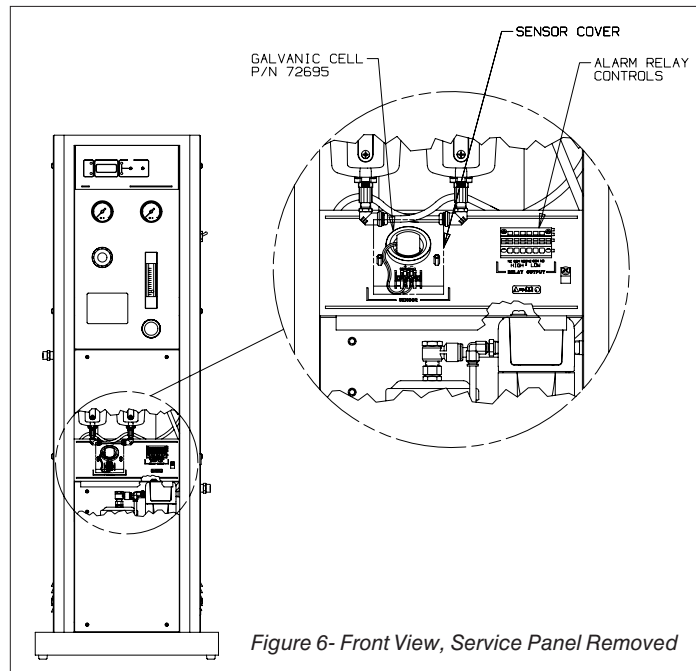

Figure 6- Front View, Service Panel Removed

**Alarm Set Points**

The high and low limits of the alarm may be set anywhere between 0.5% and 25% oxygen, depending on the process limitations. To set the high alarm set point, press the alarm set switch upward and adjust the high potentiometer until the display shows the desired high alarm set point. To set the low alarm set point, press the alarm set switch downward and adjust the low potentiometer until the display shows the desired low alarm set point.

**Alarm Relay Contacts**

The oxygen analyzer also includes high and low alarm relay contacts located inside the service panel. The oxygen analyzer, through the use of the alarm relay contacts, may be used to control the outlet stream (see Figure 7). For example, a high or low oxygen concentration could signal a remote alarm, open a backup supply of nitrogen, or shut the generator down for protection of downstream equipment or processes. The alarm relay contacts must be wired by a qualified electrician. Both the high and low oxygen alarm conditions are provided with three relay outputs: a common (C), a normally open (NO), and normally closed (NC).



**To eliminate the possibility of electrical shock, disconnect the power cord before wiring the alarm relay contacts to outside circuitry.**



**The relay contacts are rated for 250 VAC, 5 amps resistive or 3 amps inductive load or 24 VDC 5 amps resistive or 3 amps inductive load. Do not exceed these values in order to maintain the instrument safety certification.**

**N2-14, N2-22, N2-35, N2-14A, N2-22A, N2-35A Parker Balston Nitrogen Generators**

Figure 7- Sample Wiring Schematic for Alarm Relay Contacts

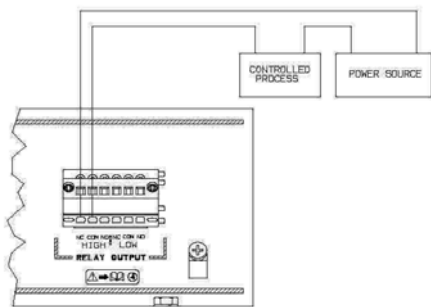

The customer is responsible for the circuitry utilizing these relay outputs and should use good engineering safety practices in the design of this circuitry.

- 1 Strip all connecting wires to 1/4" to 3/8" (6mm to 9mm) using wire strippers.
- 2 Insert small screwdriver into the hole below the wire connection point and press to open connector.
- 3 Slide the stripped wire end into the connection port until it "bottoms out".
- 4 Remove the screwdriver to clamp the wire into the connection port. Pull the wire gently to test integrity of the connection. Repeat this procedure from step 2 if the wire releases easily.
- 5 Thread wires through electrical access opening on right side of generator (see Figure 1).

**Operation: Calibration (Models N2-14A, N2-22A and N2-35A only)****Startup**

Plug the power cord into the power receptacle of the generator, and plug the opposite end into a nearby wall outlet with earth ground protection. (**Note:** There is no power switch on the generator. The oxygen analyzer is energized when the generator is plugged in.)

The inlet and outlet connections to the Parker Balston Nitrogen Generator must be checked for leaks prior to system start-up. After the system is properly installed and checked for leaks, the inlet gate valve can be opened to introduce compressed air to the system.

During start-up and adjustment of the system, the nitrogen produced by the unit will be of variable purity. If the application for the nitrogen is critically dependent on purity, the nitrogen produced during start-up or adjustment should be vented.

If the outlet nitrogen flow is closed, the system will still consume compressed air. The inlet air is simply vented to atmosphere through the permeate ports of the membrane module.

**Oxygen Analyzer Calibration**

**CAUTION: the oxygen analyzer will not provide accurate readings unless calibrated on a regular basis.**

The oxygen analyzer is calibrated prior to shipment; however, Parker Balston strongly recommends re-calibrating the unit prior to initial start-up. After the initial start-up, the analyzer should be calibrated on a bi-weekly basis until a suitable schedule is determined, based upon the level of accuracy required by the application.

There are two methods of calibrating the oxygen analyzer: the two point method and the single point method. In the two point method, the first point in the calibration range is set to zero using a zero gas (zero percent oxygen), and the second point in the range is set to a known percentage of oxygen using a span gas (known quantity of oxygen, per gas supplier) or compressed air (20.9% oxygen). In the single point method, only one point in the calibration range is set, using either span gas or compressed air. Maximum accuracy in oxygen concentration monitoring will be achieved if the oxygen concentration in the span gas is within the range of the expected oxygen concentration in the process stream and the pressure of the gas closely approximates the pressure of the nitrogen gas (See Figure 3 for calibration controls).

Oxygen analyzer readings should be checked and the analyzer re-calibrated on a routine basis. If the nitrogen purity level falls below the desired level, re-calibrate the analyzer or adjust the flow until the proper nitrogen purity level is reached.

**Two Point Calibration**

The procedure for the **two point calibration method** is as follows:

- 1 Throw the toggle switch on the back of the unit to the upright position, toward the calibration port.
- 2 Connect a tank of zero gas to the calibration port. (Gas pressure should be approximately equal to operating pressure.)
- 3 Allow the zero gas to flow through the unit until the reading on the oxygen concentration display stabilizes.
- 4 Adjust the Zero potentiometer until the oxygen concentration display reads zero.
- 5 Disconnect the zero gas from the calibration port, and connect a tank of span gas or a source of clean compressed air (set gas pressure to operating pressure).

**N2-14, N2-22, N2-35, N2-14A, N2-22A, N2-35A Parker Balston Nitrogen Generators****Single Point Calibration**

- 6 Allow the reading to stabilize, and adjust the Span potentiometer until the reading on the oxygen concentration display reads the known percent (span gas) or 20.9% (compressed air).
- 7 Disconnect the calibration gas and throw the toggle switch to the downward position to resume sampling the nitrogen stream.

The procedure for the **single point calibration method** is as follows:

- 1 Throw the toggle switch on the back of the unit to the upright position, toward the calibration port.
- 2 Connect a tank of span gas or a source of clean compressed air to the calibration port (set gas pressure to operating pressure).
- 3 Allow the gas or air to flow through the analyzer until the reading on the oxygen concentration display stabilizes.
- 4 Adjust Span potentiometer until the reading on the oxygen concentration display reads the known percent (span gas) or 20.9% (compressed air).
- 5 Disconnect the calibration gas and throw the toggle switch to the downward position to resume sampling the nitrogen stream.

(Note: Parker recommends the use of a span gas with an oxygen content between 1% and 10%.)

**Operation: Adjustment Procedure (All Models)****System Adjustment for Desired Outlet Purity**

The user must determine the nitrogen purity, flow rate, and pressure required by the application prior to adjusting the system for desired outlet nitrogen purity and flow rate. The inlet air pressure must be constant in order for the system to supply nitrogen of consistent purity to the application. The inlet pressure to the Parker Balston Nitrogen Generator should be maximized (within process and generator parameters) to optimize the operation of the membrane module. The required inlet air flow rate and all flow and purity specifications for different operating conditions are shown in the Adjustment Procedures in the Operation Section.

**Note:** There will be a 10 to 15 psig pressure differential between the pressure of the compressed air supply at the inlet and the operating pressure of the membrane module. All flow rate/purity charts are based on the **operating pressure** of the membrane module. This pressure loss must be taken into account when determining the inlet pressure which will deliver the desired purity and flow of nitrogen from the generator.

To adjust the outlet pressure, pull the pressure regulator knob out, adjust the pressure, and push the cap back in to lock the setting. To adjust the dimensionless flow meter, turn the control knob until the middle of the ball reads the desired setpoint.

**A. Atmospheric pressure applications (<10 psig/0.7 barg)**

If the Parker Balston Nitrogen Generator is being used to deliver nitrogen at or near atmospheric pressure (e.g. purging or blanketing applications), use the following procedure for start-up and adjustment of the system

- 1 Open the (customer installed) inlet air gate valve.
- 2 Adjust the (customer installed) inlet air pressure regulator until the Operating Pressure gauge (see Figure 1) shows the operating pressure reading necessary to provide the purity and flow demanded by the application, as shown in the purity/flow chart (see page 12).
- 3 Adjust the Outlet Pressure regulator (see Figure 1) until the Outlet Pressure gauge reads less than 10 psig (0.7 barg).
- 4 Consult the Nitrogen Purity Label on the control panel of the generator (or the tables on page 12), to determine the proper flowmeter setting for the required process nitrogen purity and operating air pressure. Adjust the Flow Control valve on the control panel (see Figure 1) to yield the proper flowmeter reading. The flow reading will be taken from the middle of the ball.
- 5 Allow the system to reach equilibrium at the desired flow rate, pressure, and purity parameters. This should take approximately 15 minutes.

**N2-14, N2-22, N2-35, N2-14A, N2-22A, N2-35A Parker Balston Nitrogen Generators**

---

**B. Elevated pressure applications (>10 psig/0.7 barg)**

If the Parker Balston Nitrogen Generator is being used to deliver nitrogen at an elevated pressure (>10 psig/0.7 barg), use the following procedure for start-up and adjustment of the system. (**Note:** In elevated pressure applications, the customer should install a flow controller downstream from the nitrogen generator, as detailed in the Installation section of this manual.)

- 1 Open the (customer installed) inlet air gate valve.
- 2 Adjust the (customer installed) inlet air pressure regulator until the Operating Pressure gage shows the operating pressure reading necessary to provide the purity and flow demanded by the application, as shown in the purity/flow charts (see page 12).
- 3 Turn the flow control valve to its fully open position.
- 4 Set the Outlet Pressure regulator (see Figure 1) to the desired outlet nitrogen pressure.
- 5 Consult the Nitrogen Purity Label on the control panel of the generator to determine the proper dimensionless flowmeter setting for the required nitrogen purity and generator operating pressure. Adjust the (customer installed) Flow Controller until the dimensionless flowmeter shows the correct reading (based on the Nitrogen Purity Label or the tables on page 12). The flow reading will be taken from the middle of the ball.
- 6 Allow the system to reach equilibrium at the desired flow rate, pressure, and purity parameters. This should take approximately 15 minutes.

**Note:**

If more than minor adjustments of the downstream flow controller are required to reach the desired purity level, please see the Troubleshooting section of this manual for further guidance.

**C. Receiving Tank applications**

After all the components have been properly installed (see Figure 5), the following procedure should be followed to ensure optimal operation of the entire nitrogen supply system.

- 1 Set the inlet pressure to the Parker Balston Nitrogen Generator using the customer-provided pressure regulator, and initiate the air flow through the system.
- 2 Set the flow control valve to its fully open position. The nitrogen flow meter reading should be at the top of the scale.
- 3 Close the shutoff valve to the process or instrument and open the vent valve downstream from the receiving tank to prevent substandard nitrogen from entering the process.
- 4 Fully open the Outlet Pressure regulator on the nitrogen generator, and adjust the Back Pressure Controller until the Outlet Pressure gauge on the nitrogen generator reads 10 psig (0.7 barg) less than the desired nitrogen storage pressure. Maximize the storage pressure in order to maximize the storage capacity of the selected receiving tank.
- 5 Set the flow control valve on the front panel of the nitrogen generator to the proper reading, as specified by the Nitrogen Purity Label, or the charts on the previous page.
- 6 Purge the entire system for 5 minutes, venting the initial nitrogen stream through the vent valve to atmosphere.
- 7 Close the vent valve, open the process or instrument shutoff valve to initiate the flow of nitrogen to the system.

The use of a receiving tank upstream from the process, as detailed in this literature, significantly reduces the effects of fluctuating nitrogen demand on the purity of the nitrogen process stream from the Parker Balston Nitrogen Generator. A 5-minute purge of the system (see Step 3 above) is needed each time the unit is started.

**N2-14, N2-22, N2-35, N2-14A, N2-22A, N2-35A Parker Balston Nitrogen Generators**

---

- Temperature Equilibrium** If the temperature of the inlet air to the Parker Balston Nitrogen Generator differs from the temperature of the module (i.e. ambient temperature), the system must be allowed to reach temperature equilibrium before a constant purity of nitrogen is delivered from the system. If the temperature difference is 10°F-20°F (5°C-10°C), this equilibrium period may be as long as 60 minutes. **The inlet air temperature and, more importantly, inlet air dewpoint, should not be higher than the ambient temperature, or condensation of water within the system may occur, resulting in damage to the generator.**
- Performance of the Parker Balston Nitrogen Generator is highly dependent on the temperature of the inlet air. The data on purity and flow rate presented in this bulletin is based on an inlet air temperature of 68°F (20°C). If the temperature of the inlet air at the point of use for this system varies from 68°F (20°C) by more than 5°F (3°C), the factory must be consulted for flow and purity information. If the temperature of the inlet air is expected to vary, install an Oxygen Analyzer (P/N 72-02730NA) to provide assurance that the application is supplied with the desired purity of nitrogen.
- Evaluation** The performance and operating conditions of the Parker Balston Nitrogen Generator should be checked at least once per month. This routine system check should include correcting any changes in the flowmeter reading, confirming pressure gage reading stability and operating pressure setting, and checking the downstream flowmeter (if applicable) to ensure flows are consistent with the required nitrogen purity level.
- The optimum performance of the nitrogen generator is dependent on system parameters remaining stable and accurate; as such, the use of an oxygen analyzer to monitor system performance is highly recommended.
- System Upsets** System upsets relative to pressure or flow rate will result in variations in purity of the outlet gas. System upsets relative to temperature, dewpoint, or hydrocarbon content of the inlet compressed air may result in variations of the system performance. These types of upsets should be eliminated from the compressed air delivery system to assure consistent performance of the nitrogen generator.
- Shutting Down** Proper shutdown of the nitrogen generator can be accomplished by simply closing the inlet air gate valve. If this valve is left open, the system will continue to consume compressed air. Closing the outlet flow control valve will not prevent air consumption because the membrane module permeate ports are open to atmosphere.

**N2-14, N2-22, N2-35, N2-14A, N2-22A, N2-35A Parker Balston Nitrogen Generators**

**Model N2-14 and N2-14A Minimum Purity at Operating Temperature and Flow**

MINIMUM PURITY PERCENT N <sub>2</sub>	60 psig		70 psig		80 psig		90 psig		100 psig		125 psig		145 psig	
	METER	SLPM	METER	SLPM	METER	SLPM	METER	SLPM	METER	SLPM	METER	SLPM	METER	SLPM
99.5	0.4	4.5	0.5	5.2	0.5	6.3	0.6	7.3	0.6	8.1	0.7	10.1	0.8	11.7
99.0	0.7	7.3	0.8	8.5	0.8	10.1	0.9	11.7	1.0	13.0	1.1	16.3	1.2	18.8
98.0	1.1	11.6	1.2	13.6	1.3	16.0	1.5	18.5	1.6	20.5	1.8	25.7	1.9	29.9
97.0	1.5	15.5	1.6	18.1	1.8	21.5	2.0	25.0	2.1	27.6	2.4	34.9	2.6	40.2
96.0	1.8	19.5	2.0	22.7	2.2	26.9	2.5	31.0	2.6	34.4	3.0	43.4	3.2	50.0
95.0	2.3	24.1	2.5	28.1	2.7	32.9	3.0	37.7	3.2	42.0	3.6	52.7	3.9	60.8

**Model N2-14 and N2-14A Minimum Purity at Operating Temperature and Flow**

MINIMUM PURITY PERCENT N <sub>2</sub>	4 Bar		5 Bar		6 Bar		7 Bar		8 Bar		9 Bar		10 Bar	
	METER	SLPM	METER	SLPM	METER	SLPM	METER	SLPM	METER	SLPM	METER	SLPM	METER	SLPM
99.5	0.4	4.4	0.5	5.4	0.6	7.1	0.7	8.3	0.7	9.3	0.7	10.7	0.8	11.7
99.0	0.7	7.1	0.8	8.9	0.9	11.3	1.0	13.2	1.1	15.0	1.2	17.1	1.2	18.8
98.0	1.1	11.3	1.2	14.1	1.5	17.9	1.7	20.9	1.8	23.9	1.8	26.9	1.9	29.9
97.0	1.4	15.0	1.7	18.8	2.0	24.2	2.2	28.1	2.4	32.1	2.5	36.6	2.6	40.2
96.0	1.8	18.9	2.1	23.6	2.5	30.0	2.8	35.0	3.0	40.1	3.1	45.5	3.2	50.0
95.0	2.2	23.3	2.6	29.1	3.0	36.5	3.4	42.6	3.7	48.6	3.8	55.2	3.9	60.8

**Model N2-22 and N2-22A Minimum Purity at Operating Temperature and Flow**

MINIMUM PURITY PERCENT N <sub>2</sub>	60 psig		70 psig		80 psig		90 psig		100 psig		125 psig		145 psig	
	METER	SLPM	METER	SLPM	METER	SLPM	METER	SLPM	METER	SLPM	METER	SLPM	METER	SLPM
99.5	0.7	7.7	0.8	9.0	0.9	10.5	0.9	12.0	1.0	13.3	1.1	16.7	1.2	19.2
99.0	1.1	11.5	1.2	13.5	1.3	15.8	1.4	18.2	1.5	20.2	1.7	25.0	1.9	29.4
98.0	1.6	17.5	1.8	20.4	2.0	24.0	2.2	27.6	2.3	30.7	2.6	38.3	2.9	44.6
97.0	2.2	23.1	2.4	26.9	2.7	31.8	2.9	36.6	3.1	40.6	3.5	50.8	3.8	59.0
96.0	2.6	27.8	2.9	32.4	3.3	39.0	3.6	45.4	3.8	50.4	4.4	63.6	4.7	73.2
95.0	3.3	35.4	3.6	41.3	4.0	48.2	4.4	55.1	4.6	61.2	5.3	77.1	5.7	88.8

**Model N2-22 and N2-22A Minimum Purity at Operating Temperature and Flow**

MINIMUM PURITY PERCENT N <sub>2</sub>	4 Bar		5 Bar		6 Bar		7 Bar		8 Bar		9 Bar		10 Bar	
	METER	SLPM	METER	SLPM	METER	SLPM	METER	SLPM	METER	SLPM	METER	SLPM	METER	SLPM
99.5	0.7	7.5	0.8	9.3	1.0	11.6	1.1	13.5	1.2	15.5	1.2	17.4	1.2	19.2
99.0	1.0	11.1	1.2	14.0	1.5	17.6	1.6	20.6	1.8	23.6	1.8	26.0	1.9	29.4
98.0	1.6	17.0	1.9	21.2	2.2	26.7	2.5	31.2	2.7	35.6	2.7	39.9	2.9	44.6
97.0	2.1	22.4	2.5	27.9	3.0	35.4	3.3	41.3	3.6	47.1	3.7	53.1	3.8	59.0
96.0	2.5	26.9	3.0	33.6	3.7	44.0	4.1	51.2	4.4	58.5	4.6	66.8	4.7	73.2
95.0	3.2	34.2	3.8	42.8	4.4	53.3	4.9	62.1	5.4	71.0	5.6	80.9	5.7	88.8

**Model N2-35 and N2-35A Minimum Purity at Operating Temperature and Flow**

MINIMUM PURITY PERCENT N <sub>2</sub>	60 psig		70 psig		80 psig		90 psig		100 psig		125 psig		145 psig	
	METER	SLPM	METER	SLPM	METER	SLPM	METER	SLPM	METER	SLPM	METER	SLPM	METER	SLPM
::/6	2/2	22/9	2/3	24/9	2/4	27/2	2/6	29/6	2/7	31/6	2/8	36/4	2/:	3:/:
::/1	2/7	28/6	2/9	31/5	3/1	34/:	3/3	38/6	3/4	41/7	3/7	48/:	3/9	55/4
:9/1	3/6	37/3	3/8	41/8	4/1	47/2	4/4	52/5	4/6	57/1	5/1	68/9	5/4	77/9
:8/1	4/5	46/:	4/7	51/6	4/:	57/2	5/2	63/1	5/5	68/9	6/2	85/8	6/5	94/8
:7/1	5/1	53/9	5/5	61/2	5/:	6:/1	6/5	78/9	6/8	86/3	7/6	:5/7	8/1	21:/3
:6/1	5/:	63/2	6/5	71/8	7/1	82/3	7/6	92/9	7/:	:1/:	8/:	225/6	9/6	242/:

**Model N2-35 and N2-35A Minimum Purity at Operating Temperature and Flow**

MINIMUM PURITY PERCENT N <sub>2</sub>	4 Bar		5 Bar		6 Bar		7 Bar		8 Bar		9 Bar		10 Bar	
	METER	SLPM	METER	SLPM	METER	SLPM	METER	SLPM	METER	SLPM	METER	SLPM	METER	SLPM
99.5	1.1	11.4	1.3	14.3	1.5	17.9	1.7	20.9	1.8	23.9	1.8	26.3	1.9	29.9
99.0	1.6	17.0	1.9	21.2	2.2	26.6	2.5	31.1	2.7	35.4	2.7	39.5	2.8	44.3
98.0	2.4	25.4	2.8	31.8	3.3	40.1	3.7	46.7	4.1	53.4	4.2	60.5	4.3	66.8
97.0	3.3	35.0	3.7	41.7	4.2	50.3	4.7	58.7	5.1	66.9	5.5	79.5	5.4	83.7
96.0	3.9	41.4	4.6	51.9	5.5	65.6	6.1	76.4	6.6	87.3	6.8	99.0	7.0	109.2
95.0	4.7	50.4	5.6	62.9	6.6	79.1	7.3	92.3	8.0	105.5	8.3	120.0	8.5	131.9

**Notes**

- The flow meter reading is dimensionless. Read flowmeter at the middle of the ball. The actual flow at various operating pressures is converted into SLPM (standard liters per minute) in the purity label on the unit.
- Minimum purity is shown on the purity label is in percent nitrogen. All nitrogen purities are ± 0.5%.
- All data shown in the flow chart is based on an operating temperature of 68°F (20°C).
- At inlet air temperatures less than 68°F (20°C) or greater than 82°F (28°C) consult factory for flow rates.

**N2-14, N2-22, N2-35, N2-14A, N2-22A, N2-35A Parker Balston Nitrogen Generators**

**Maintenance**



**Before servicing the Parker Balston Nitrogen Generator, isolate the unit from the compressed air supply and fully depressurize the system. Replacement component locations are shown in Figure 8.**

**All maintenance activities for the Parker Balston Nitrogen Generators should be performed by suitable personnel using reasonable care.**

The required maintenance for the Parker Balston Nitrogen Generator consists of changing the prefilter and final filter cartridges, replacing the activated carbon filter, changing the galvanic cell (Models N2-14A, N2-22A, and N2-35A), calibrating the oxygen analyzer, and monitoring the performance of the system. All filters are located behind the front filtration access panel. The recommended service schedule and replacement part numbers are outlined in the Service Schedule at the end of this section. The locations of all serviceable parts are shown in Figure 8. Replacement coalescing filter cartridges, final membrane filter cartridges, and activated carbon filters have been assembled into a maintenance kit (P/N MK7572C) which may be purchased through your local representative. The MK7572C Maintenance Kit provides one year of filtration replacement components.

Servicing the Parker Balston Nitrogen Generator takes approximately 15 minutes. Remove the filter access panel using a Phillips head screwdriver to access filtration components.

**Filter Cartridge Replacement**

Remove the filter cartridges from the filter housings by: loosening the collar from the filter assembly, lowering the filter bowl away from the filter head, and unscrewing the element retainer from the base of the cartridge. Insert the new filter cartridge and reassemble the housing in reverse order. Be sure to install the proper grade filter in the proper housing (the housings are labeled).

**Activated Carbon Filter Replacement**

The only tool required to change the activated carbon filter is a 7/16" (or adjustable) wrench or socket wrench. To change the activated carbon filter, disconnect the tubing from the press fittings on the inlet and outlet ports of the scrubber. (To remove the tubing from the press fittings, push the tubing into the fitting, hold the collar of the fitting back, and pull the tubing out of the fitting.) Remove the 4 bolts that hold the scrubber to the generator chassis (the mounting bracket should stay on the scrubber). Replace with new scrubber and re-assemble. Please note that as of October 1, 2002, Parker has discontinued the core credit and rebuild program for activated carbon towers and compressors. These items may be disposed of locally by the customer. If there are disposal concerns, please contact the Technical Services Department at 800-343-4048, 8AM to 5PM Eastern Time.

**Do not remove the collar on the Hydrocarbon Scrubber.**

**Follow-up**

The performance of the system should be reviewed on a monthly basis. This review should include checking the settings for inlet pressure, outlet flow rate, and outlet pressure. If these readings have changed from the original settings, adjustments must be made as described in the Adjustment Procedure section of this bulletin. Calibration must be performed routinely on any oxygen analyzer being used with the system. Consult the manufacturer for procedure and frequency of calibration.

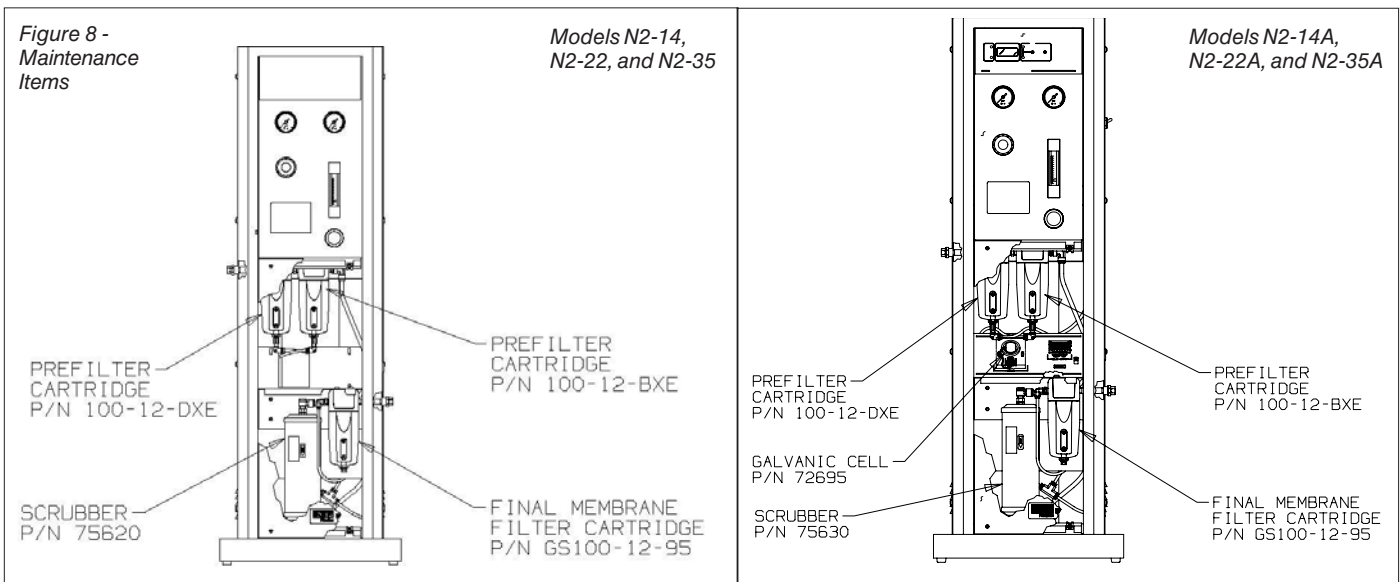

**N2-14, N2-22, N2-35, N2-14A, N2-22A, N2-35A Parker Balston Nitrogen Generators**

**Maintenance**

**Galvanic Cell Replacement**  
(Models N2-14A, N2-22A, and N2-35A only)



**Disconnect generator from power supply before replacing galvanic cell sensor.**

The galvanic cell sensor degrades over time and should be replaced on an annual basis (P/N 72695A). The only tools needed for this replacement are a Phillips screwdriver, a small screwdriver, and wire strippers. The procedure for changing the sensor is outlined below and takes approximately 10 minutes.

- 1 Remove filtration access panel and cell cover to expose galvanic cell holder (see Figure 8).
- 2 Disconnect old cell wires from connectors.
- 3 Strip replacement sensor connecting wires to 1/4" to 3/8" (6mm to 9mm) using wire strippers.
- 4 Connect the stripped wires to the screw connections provided being sure to maintain the proper polarity (black -, red +).
- 5 Replace filter access panel.

**Fuse Replacement**  
(Models N2-14A, N2-22A, and N2-35A only)



**This equipment has fuses in both neutral and phase lines. Use care when servicing.**

Occasionally, one or both of the fuses (P/N 13221) in the generator may burn out. The fuses are located in the power receptacle on the back of the generator. **Before servicing the fuses, disconnect the power cord from the power supply.** Both fuses should be checked each time fuse replacement is warranted. To access the fuses, use a small screwdriver to remove the holder located in the power receptacle of the generator. Replace either one or both fuses as necessary and re-assemble.



**For continued protection against risk of fire, replace only with fuse of specified rating.**

**Cleaning**



The product is not intended for use in extremely dirty environments. If necessary, the Parker Balston Nitrogen Generator may be wiped clean with a dry cloth on an as needed basis. **Do not use water, aerosols, or other cleaning agents to clean the unit. Use of any liquid detergent to clean the generator could present an electrical hazard.**

**Service Schedule**

Item	1st Stage	2nd Stage	Hydrocarbon Scrubber	Final Filter	Galvanic Cell(1)
Replacement Element	100-12-DXE	100-12-BXE	B04-0074	GS-100-12-95	72695
Change Frequency	6 Months	6 Months	6 Months	6 Months	Annual
Maintenance Kit MK7572C	2 Each	2 Each	2 Each	2 Each	—

1 For Models N2-14A, N2-22A, and N2-35A. Galvanic Cell not included in Maintenance Kit. Must be ordered separately.

**N2-14, N2-22, N2-35, N2-14A, N2-22A, N2-35A Parker Balston Nitrogen Generators**

**System Specifications**

Model Number	N2-14, N2-22, N2-35	N2-14A, N2-22A, N2-35A
CSA Certification Standard	—	CSA 22.2 No. 1010.1-1992
IEC 1010 Installation Category	—	Category II
IEC 1010 Pollution Category	—	Degree 2
Purity (% Nitrogen)	95.0-99.5	95.0-99.5
Flow Capacity	See Purity/Flow Charts (Operation/Adjustment Procedure Section)	
Atmospheric Dewpoint	-58°F (-50°C)	-58°F (-50°C)
Particles > 0.01µm	None	None
Suspended Liquids	None	None
Commercially Sterile	Yes	Yes
Inlet Air Consumption	See Air Consumption table (below)	
Min./Max. Operating Pressure	60/145 psig (4.0/10 barg)	60/145 psig (4.0/10 barg)
Maximum Pressure Drop	15 psig (1barg)	15 psig (1 barg)
Ambient Operating Temperature Range	60°F - 110°F (15°C - 43°C)	60°F - 95°F (15°C - 35°C)
Recommended Ambient Operating Temp.	68°F (20°C)	68°F (20°C)
Inlet Air Temp. Range	60°F - 95°F (15°C - 35°C)	60°F - 95°F (15°C - 35°C)
Maximum Recommended Inlet Air Temp.	68°F (20°C)	68°F (20°C)
Electrical Requirements (1)	None	120 VAC/240 VAC, 50/60 Hz
Dimensions	16" w x 16" d x 50" h (40 cm x 40 cm x 127 cm)	
Shipping Weight	N2-14: 75 lbs.(34 kg) N2-22: 101 lbs.(46 kg) N2-35: 115 lbs.(52.2 kg)	N2-14A: 75 lbs.(34 kg) N2-22A: 106 lbs.(48 kg) N2-35A: 119 lbs.(54.0 kg)

1 Main supply line voltage must be within 10% of nominal rated voltage for the generator.

**Inlet Air Consumption at Pressure and Purity @68°F (20°C)**

Operating Pressure		Purity (% N <sub>2</sub> )	Inlet Air Required		
psig	barg		N2-14, N2-14A SLPM	N2-22, N2-22A SLPM	N2-35, N2-35A SLPM
145	10	99	105	165	248
145	10	95	158	231	343
125	8.6	99	91	140	212
125	8.6	95	137	200	298
100	6.9	99	73	113	171
100	6.9	95	109	159	236
80	5.5	99	57	88	133
80	5.5	95	86	125	185

**Parts and Accessories**

Item	Part Number
Sensor Seal Set	22172
Fuse	13221
Galvanic Cell (Models N2-14A, N2-22A, and N2-35A only) (2)	72695A
External Activated Carbon Scrubber	72-905
Oxygen Analyzer	72-02730NA
Replacement Membrane Module (Models N2-14 and N2-14A)	B04-0142
(Models N2-22 and N2-22A)	B04-0143
(Models N2-35 and N2-35A)	B04-0151

2 Galvanic Cell not included in Maintenance Kit. Must be ordered separately.



**N2-14, N2-22, N2-35, N2-14A, N2-22A, N2-35A Parker Balston Nitrogen Generators****Oxygen Analyzer System Specifications**  
(Models N2-14A, N2-22A, and N2-35A only)

Display	LED type
Accuracy	±1% Full scale calibrated span, after 30 min. stabilization
Min./Max. inlet pressure (calibration port)	2 psig/145 psig (0.14 barg/10 barg)
Sensor type	Galvanic cell
Sensor life	up to 1 year
Response time	12 seconds
Digital display	00.0 to 99.9% oxygen
Span concentration	.1 to 99.9% oxygen
Required calibration	2 weeks
Alarm outputs	DPDT relay contacts 3 amp, 250 VAC Rating, 1/8 HP resistive

**Notes and Cautions****Notes**

- 1 The flow meter reading is dimensionless. Read flowmeter at the top of the ball. The actual flow at various operating pressures is converted into SLPM (standard liters per minute) in the purity label flow chart on the unit.
- 2 Minimum purity shown on the purity label in percent nitrogen. All nitrogen purities are ± 0.5%. If a more accurate reading is required, use the Balston 72-730-V883 Oxygen Analyzer or a trace analyzer.
- 3 All data shown in the flow chart is based on an operating temperature of 68°F (20°C).
- 4 At inlet air temperatures less than 68°F (20°C) or greater than 82°F (28°C) consult factory for flow rates.

**Cautions**

- 1 The Parker Balston Nitrogen Generator should be installed in an area with adequate ventilation to reduce the flammability of the oxygen-rich permeate stream. The system should not be located in an area where the permeate stream poses the risk of explosion or combustion.
- 2 **Nitrogen is nontoxic and largely inert. It can act as a simple asphyxiant by displacing oxygen in air. Inhalation of nitrogen in excessive concentrations can result in unconsciousness without any warning symptoms such as dizziness, fatigue, etc.**
- 3 The **maximum** operating pressure of the system is 145 psig (10 barg). Operating the nitrogen generator at pressures above 145 psig (10 barg) will result in damage to the membrane.
- 4 The **recommended** operating inlet air temperature for the nitrogen generator is 68°F (20°C) or less. If the inlet air temperature will be higher than the ambient temperature, the compressed air should be cooled and filtered, to remove water and oil, prior to heating for introduction to the nitrogen generator. **Do not use high temperature compressed air directly from the compressor, this will permanently damage the membranes.**
- 5 The **maximum** operating inlet air temperature of the Parker Balston Nitrogen Generator is 95°F (35°C). If the inlet air temperature is above 95°F (35°C), the longevity of the membrane will be reduced and the warranty will be void.
- 6 The drain lines from the first two stages of filtration should be piped away to an appropriate collection vessel or waste treatment system (open to atmospheric pressure) to avoid any possible re-entrainment of liquid in the air which feeds the membrane module.
- 7 Changes in inlet pressure or outlet flow demand will alter the nitrogen purity.
- 8 **Use of any valve other than a gate valve (or other slow-opening valve) on the inlet air supply will cause damage to the membrane module.**



**Troubleshooting and Service**



**All troubleshooting and service activities should be performed by suitable personnel using reasonable care.**

**Troubleshooting**

Symptom	Course of Action
<b>Loss of outlet pressure</b>	Check that the flow control valve on the generator is fully open and control the flow with a valve at the process. Check operating pressure to assure that it is greater than 60 psig (4.1 barg). Check the system for leaks.
<b>Loss of outlet flow</b>	Check operating pressure to assure that it is greater than 60 psig (4.1 barg). Check setting of flow control valve. Adjust if necessary. Check the system for leaks.
<b>Purity is lower than specified for operating conditions</b>	Check setting of flow rate compared to specification. Check the operating pressure to assure that it has not varied from the original reading. Check the system for leaks. Measure the temperature and dewpoint of the inlet air. The recommended temperature is 68°F (20°C) and the recommended dewpoint 60°F (15°C) or lower. Calibrate oxygen analyzer (if needed).
<b>Air leak through drains of prefilters</b>	Remove tubing from the drain and hold finger over drain opening for a few seconds to allow pressure to build, and drain to seal. Check inlet pressure. It should be greater than 15 psig (1 barg) to seal drain. Remove bowl from filter assembly and rinse with water. If leak persists, replace automatic float drain. (P/N 21552)
Symptom - Oxygen Analyzer	Course of Action
<b>Display varies</b>	Check process flow demand Check sensor light Check sample lines for leaks
<b>Alarm stays on</b>	Check set points
<b>Limited range during calibration</b>	Replace sensor (P/N 72695A)

**Don't Forget To:**

- 1 Complete and mail your registration card.
- 2 Keep your product certification in a safe place.
- 3 Call the Technical Services Department at **800-343-4048**, 8 AM to 5 PM Eastern Time with any questions. (For locations outside North America, please contact your local representative.) Send emails to: BalstonTechSupport@Parker.com.

**Serial Numbers**

The serial number label for the unit is on the left side of the generator, below the inlet port. For your own records, and in case service is required, please record the following:

DATE IN SERVICE \_\_\_\_\_ SERIAL NO. \_\_\_\_\_

**Please have the serial number available when calling for assistance.**



**Explanation of Warning Symbols**

**Symbol**

**Description**



Caution, refer to accompanying documents for explanation.

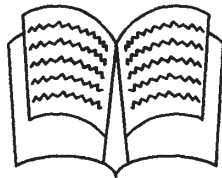

Refer to Installation and Operation Manual, warning note #3 for explanation.



Caution, risk of electric shock.



Surface may be hot and could cause burns to the skin (found on inside of some units).



Under certain conditions, metal cabinet will be warm to touch (70°C).

**Warranty (NORTH AMERICA ONLY)**  
**(FOR INFORMATION CONTACT YOUR LOCAL REPRESENTATIVE)**

Parker Hannifin guarantees to the original purchaser of this product, that if the product fails or is defective within 12 months from the date of purchase, when this product is operated and maintained according to the instructions provided with the product, then Parker guarantees, at Parker's option, to replace the product, repair the product, or refund the original price for the product. This warranty applies only to defects in material or workmanship and does not cover: ring and valve wear on compressors, routine maintenance recommended by the instructions provided with this product, or filter cartridges. Any modification of the product without written approval from Parker will result in voiding this warranty. Complete details of the warranty are available on request. This warranty applies to units purchased and operated in North America.





**Parker Hannifin Corporation**  
Filtration and Separation Division  
242 Neck Road, P.O. Box 8223  
Haverhill, MA 01835-0723  
Tel: 978-858-0505 Fax: 978-858-0625

**Parker Hannifin UK Ltd**  
Filter Division Europe  
Hermitage Court, Hermitage Lane  
Maidstone, Kent ME16 9NT, England  
Tel: +44 (01622) 723300 Fax: +44 (01622) 728703

