

Parker Balston® Model N2-04 Nitrogen Generator

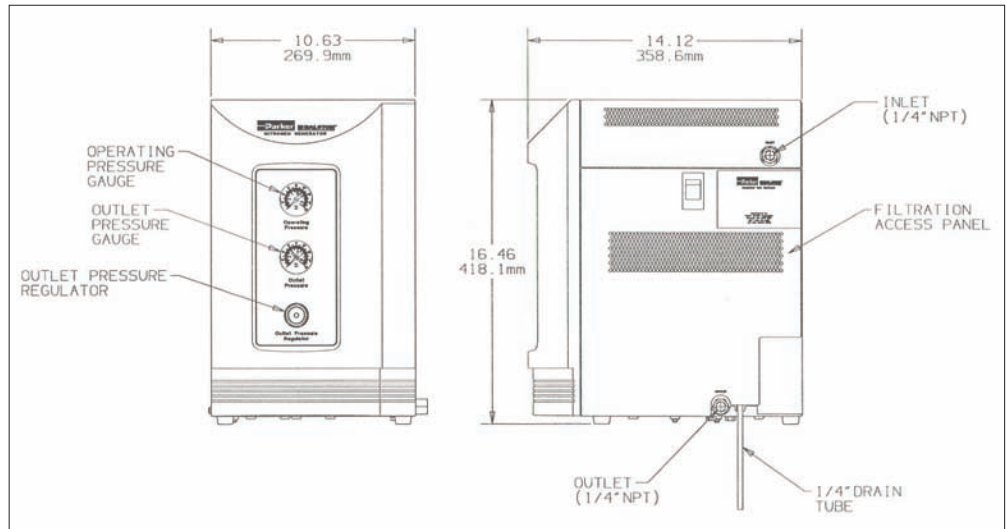

Figure 1 - N2-04 Nitrogen Generator

These instructions must be thoroughly read and understood before installing and operating this product. Failure to operate this product in accordance with the instructions set forth in this manual and by other safety governing bodies will void the safety certification of this product. If you have any questions or concerns, please call the Technical Services Department at 800-343-4048, 8 AM to 5 PM Eastern Time or email at balstontechsupport@parker.com. For other locations outside North America, please contact your local representative.

General Description

The Parker Balston N2-04 Nitrogen Generator is a completely engineered system which will convert a compressed air supply into 95% to 99% purity compressed nitrogen. The system is based on state-of-the-art membrane separation technology. Hollow fiber membranes are used to separate air into a concentrated nitrogen output stream and an oxygen enriched permeate stream.

Engineered System

The N2-04 Nitrogen Generator includes all the components required to convert compressed air into high purity nitrogen (see Figure 1). The user need only connect a supply of compressed air to the inlet of the nitrogen generator and connect the outlet of the generator to the process requiring high purity nitrogen.

The flow schematic on page 2 (Figure 2) shows all of the major components of the system. The system can be broken down into four primary functional groups. These are: prefiltration, air separation, controls, and final filtration.

Oxygen Monitoring



In hazardous applications where the oxygen content in nitrogen is critical (i.e. blanketing explosive chemicals or packaging food for extended shelf life), an oxygen monitor or trace analyzer should be used in conjunction with safety interlocks and/or alarm systems to assure proper nitrogen purity levels at all times.

CELL: Draft

Bulletin TI-N2-04F



Prefiltration

Two stages of coalescing prefiltration are incorporated into the N2-04 Nitrogen Generator to protect the membrane module from contamination. These filters are located behind the filtration access panel, and they remove liquids and particulate matter from the incoming air supply. The filters are equipped with float drains which automatically open to empty any liquids which accumulate inside the filter housing. The drains are connected to 1/4" O.D. plastic tubing which discharges to atmosphere at the back of the nitrogen generator (see Figure 1).

Air Separation

Air separation takes place in the membrane module. This module consists of bundles of hollow fiber membranes. The inlet air enters the center bore of these fibers and travels the length of the fibers. As the air passes through these hollow fibers, oxygen and water molecules pass through the membrane wall at a higher rate than nitrogen molecules. This results in a high purity, dry nitrogen gas stream exiting the membrane module. The oxygen enriched permeate stream exits the membrane module through ports on the side of the module at a very low pressure.

Final Filtration

Final filtration consists of a .01 micron (absolute) membrane filter. The final membrane filter will assure the user a clean, commercially sterile supply of high purity nitrogen.

Controls

The controls in the Balston Nitrogen Generator consist of an inlet pressure gauge, an outlet pressure gauge, and a pressure regulator (see Figure 1). Proper use of these controls will assure the user of a 95% to 99% nitrogen outlet stream. The pressure gauges, which are mounted on the front panel, measure operating pressure and outlet pressure. The outlet pressure regulator allows the user to set the pressure of the emergent nitrogen process stream.

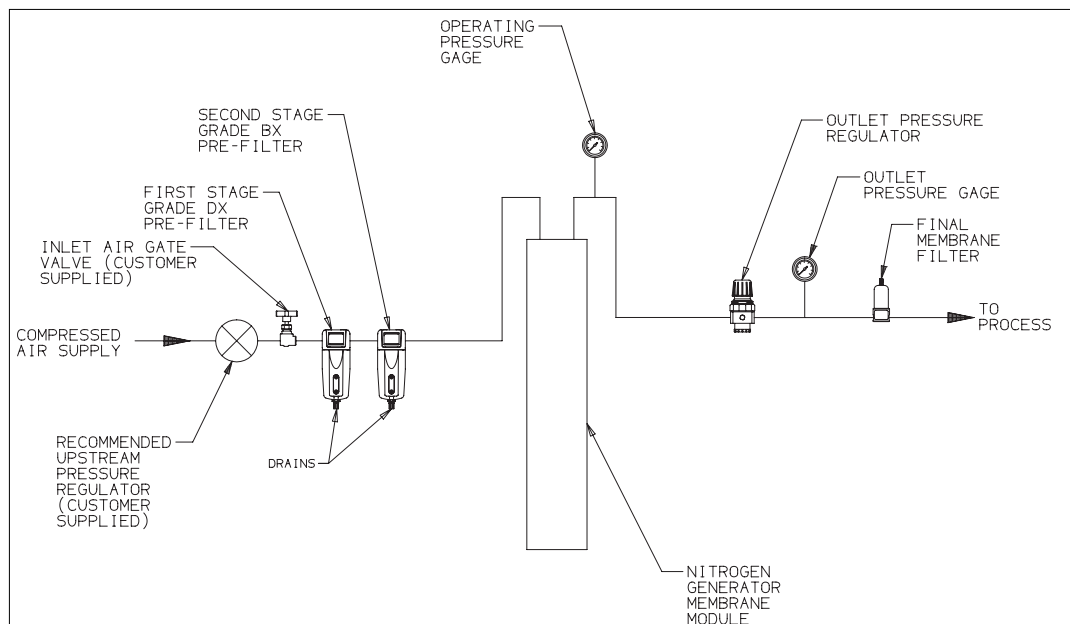

Installation

General

The N2-04 Nitrogen Generator is a free-standing unit but can be wall mounted.

The inlet and outlet ports are 1/4" female NPT. A 1/4" male connector which will withstand 145 psig (10 barg) and 90 SCFH (43 SLPM) should be used to connect to the nitrogen generator.

Shutoff Valve - A shutoff valve should be installed directly upstream from the nitrogen generator to facilitate routine maintenance and troubleshooting procedures. **Use only a gate valve or other slow-opening valve upstream from the generator.** Use of a valve which is not slow-opening will pressurize the membrane too quickly and may cause membrane rupture. Membrane failures resulting from improper valve installation will not be covered under warranty.

Pressure Regulator - A pressure regulator should be installed directly upstream from the nitrogen generator to set and maintain the inlet air pressure. Maintaining a constant inlet air pressure is critical to the performance of the system.

Flow Controller - If the application requires nitrogen at pressures higher than 10 psig (0.7 barg), or if the downstream equipment does not have flow control, install a flow controller downstream from the nitrogen generator, close to the point of use (see elevated pressure section, pg. 4).

Location

The Nitrogen Generator should be located indoors, protected from severe weather conditions, and free from excessive ambient dust or dirt. Do not install the generator outdoors. The ambient temperature of the air surrounding the generator must be between 60°F and 110°F (15°C and 43°C). Installation of the unit in an area where the ambient temperature exceeds 110°F(43°C) or falls below 60°F(15°C) may affect the performance and/or life of the system. Allow a minimum of 6" (15 cm) clearance on all sides of the generator.



The environment surrounding the Nitrogen Generator should be adequately ventilated. The N2-04 creates a 30% to 40% oxygen permeate stream which may pose a flammability problem in an oxygen-sensitive environment.



Nitrogen is nontoxic and largely inert. It can act as a simple asphyxiant by displacing oxygen in air. Inhalation of nitrogen in excessive concentrations can result in unconsciousness without any warning symptoms such as dizziness, fatigue, etc.

Utilities

Compressed Air - The N2-04 Nitrogen Generator requires a source of clean, dry compressed air for operation. The incoming air should be between 60°F and 110°F (15°C and 43°C) and be relatively free of water, compressor oil, hydrocarbons, and particulate matter. An oil content <0.01 mg/m³ is recommended. The compressed air dewpoint is recommended to be 40°F (5°C) at 145 psi. The inlet pressure of the compressed air supply should be regulated to 60 psig to 145 psig (4.1 barg to 10 barg).



The maximum operating pressure of the system is 145 psig (10 bar). Operating the Nitrogen Generator at pressures above 145 psig (10 bar) will result in damage to the membrane.

Note: Do not use high temperature air directly from the compressor!

The maximum operating inlet air temperature of the Nitrogen Generator is 110°F (43°C). If the inlet air temperature is above this specification, the longevity of the membrane will be reduced. Changes in inlet pressure or outlet flow requirements will alter the nitrogen purity.

Drain Lines - The 1/4" plastic drain lines from the first two stages of prefiltration (see Figure 1) should be piped away to an appropriate disposal container. The liquid in this drainage will consist primarily of water and compressor oil and should be disposed of properly.

Operation/Adjustment Procedures

Startup

The inlet and outlet connections to the N2-04 Nitrogen Generator must be checked for leaks prior to system start-up. After the system is properly installed and checked for leaks, the inlet valve can be opened to introduce compressed air to the system.

During start-up and adjustment of the system, the nitrogen produced by the unit will be of variable purity. If the application for the nitrogen is critically dependent on purity, the nitrogen produced during start-up or adjustment should be vented.

If the outlet nitrogen flow is closed, the system will still consume compressed air. The inlet air is simply vented to atmosphere through the permeate ports of the membrane module.

The inlet air pressure must be constant in order for the system to supply nitrogen of consistent purity to the application. The inlet pressure to the Nitrogen Generator should be maximized (within process and generator parameters) to optimize the operation of the membrane module.

Elevated Pressure Applications
(>10 psig/0.7 barg)

If the N2-04 Nitrogen Generator is being used to deliver nitrogen at an elevated pressure (>10 psig/0.7 barg), use the following procedure for start-up and adjustment of the system. (Note: in elevated pressure applications, the customer should install a flow controller downstream from the Nitrogen Generator, as detailed in the Installation section of this manual).

- 1 Open the (customer installed) inlet air gate valve.
- 2 Adjust the (customer installed) inlet air pressure regulator until the Operating Pressure Gauge shows the operating pressure reading necessary to provide the purity and flow demanded by the application, as shown in the table on page 6.
- 3 Set the Outlet Pressure Regulator (see Figure 1) to the desired outlet nitrogen pressure.
- 4 Allow the system to reach equilibrium at the desired flow rate, pressure, and purity parameters. This should take approximately 5 minutes.

Temperature Equilibrium

If the temperature of the inlet air to the Balston Nitrogen Generator differs from the temperature of the module (i.e. ambient temperature), the system must be allowed to reach temperature equilibrium before a constant purity of nitrogen is delivered from the system. If the temperature difference is 10°F-20°F (5°C-11°C), this equilibrium period may be as long as 60 minutes. The inlet air temperature and, more importantly, inlet air dewpoint, should not be higher than the temperature of the system, or condensation of water within the system may occur, resulting in inefficient performance of the system and/or damage to the membrane.

Performance of the Nitrogen Generator is highly dependent on the temperature of the inlet air. The data on purity and flow rate presented in this bulletin is based on an inlet air temperature of 68°F (20°C). If the temperature of the inlet air at the point of use for this system varies from 68°F (20°C) by more than 5°F (3°C), consult the factory for flow and purity information.

Evaluation

The performance and operating conditions of the N2-04 Nitrogen Generator should be checked at least once per week. This routine system check should include confirming pressure gauge reading stability and operating pressure setting, and checking the downstream flowmeter (if applicable) to ensure flows are consistent with the required nitrogen purity level.

The optimum performance of the Balston Nitrogen Generator is dependent on system parameters remaining stable and accurate; as such, the use of an oxygen analyzer to monitor system performance is highly recommended.

System Upsets

System upsets relative to pressure or flow rate will result in variations in purity of the outlet gas. System upsets relative to temperature, dewpoint, or hydrocarbon content of the inlet compressed air may result in variations of the system performance. These types of upsets should be eliminated from the compressed air delivery system to assure consistent performance of the Balston Nitrogen Generator.

Shutting Down

Proper shutdown of the Balston Nitrogen Generator can be accomplished by simply closing the inlet air gate valve. If this valve is left open, the system will continue to consume inlet compressed air. Closing the outlet flow control valve will not prevent air consumption because the membrane module permeate ports are open to atmosphere.

Maintenance

To avoid system damage and/or personal harm, isolate the nitrogen generator from the compressed air supply and fully depressurize the system.

All maintenance activities for the N2-04 Nitrogen Generator should be performed by suitable personnel using reasonable care.

Required maintenance for the nitrogen generator consists of changing the prefilter and final filter cartridges, and calibrating the performance of the system. The prefilters and final filter are located behind the filtration access panel. The recommended service schedule and replacement part numbers are outlined at the end of this section.

Replacement prefilter cartridges and final membrane filter cartridges may be ordered through your local representative. Part numbers and change frequencies are detailed below.

Follow-Up

The performance of the system should be reviewed on a monthly basis. This review should include checking the settings for inlet pressure, outlet flow rate, and outlet pressure. If these readings have changed from the original settings, adjustments must be made as described in the Adjustment Procedure section of this bulletin. Calibration must be performed routinely on any oxygen analyzer being used with the system. Consult the manufacturer for procedure and frequency of calibration.

Cleaning

The product is not intended for use in extremely dirty environments. If necessary, the N2-04 Nitrogen Generator may be wiped clean with a dry cloth on an as needed basis.

Filter Cartridge Replacement

All filter housings which require routine service are easily accessible when the filtration access panel is opened. The two coalescing prefilters are Parker Balston 2002N-0B1-DX and 2002-0B1-BX filter assemblies. Replace these filter cartridges with Balston 100-12-DX and 100-12-BX filter cartridges. When replacing the prefilter cartridges, be sure it install the proper grade filter in the proper housing (the housings are labeled). The final membrane filter is a Balston 74945-95 filter assembly. Replace this membrane filter cartridge with a Balston Grade GS 050-05-95 membrane filter cartridge.

For convenience, Parker offers a maintenance kit, P/N MK7840, which contains a one year supply of replacement filter cartridges.

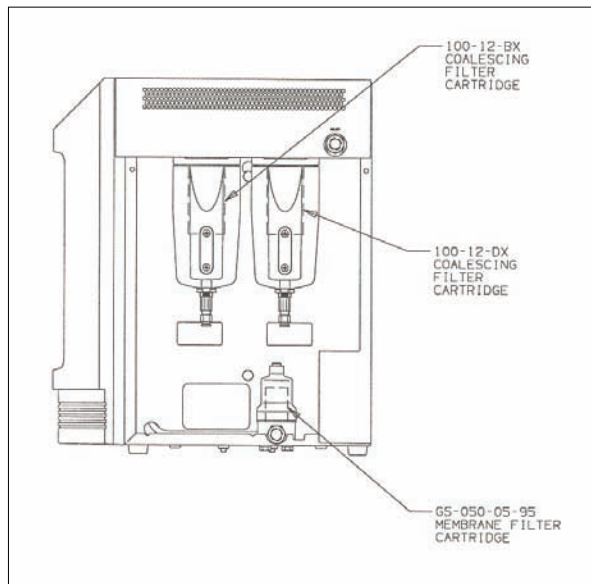

Figure 3 - Maintenance Items

To ensure consistent product performance and reliability, use only genuine Balston replacement parts and filter cartridges.

The filter cartridges in the filter assemblies are removed by: turning filter bowl 1/4 turn, lowering the filter bowl away from the filter head, and unscrewing the element retainer from the base of the cartridge. Insert the new filter cartridge and reassemble the housing in reverse order.

The time required to service all three stages of filtration is less than 15 minutes.

Service Schedule

	1st Stage	2nd Stage	Final Filter
Replacement Element	100-12-DX	100-12-BX	GS-050-05-95
Change Frequency	Annual	Annual	Annual

Note: To ensure consistent product performance and reliability, use only genuine Balston replacement parts and filter cartridges.

**Balston Nitrogen
Generation System**

Model Number	N2-04
Purity (% Nitrogen)	95% to 99%, 90 psig (6.2 barg)
Atmospheric Dewpoint	-58°F (-50°C)
Particles > 0.01µm	None
Suspended Liquids	None
Commercially Sterile	Yes
Max. Operating Pressure	145 psig (10 barg)
Maximum Pressure Drop @ 95% N ₂ , 125 psig (8.6 barg)	10 psig (0.7 barg)
Min/Max Ambient Operating Temperature	60°F / 110°F (15°C / 43°C)
Recommended Ambient Operating Temp.	68°F (20°C)
Max. Relative Humidity	80%
Altitude	2000 m Max.
Min/Max Inlet Air Temp.	60°F / 110°F (15°C / 43°C)
Maximum Recommended Inlet Air Temp.	68°F (20°C)
Dimensions	11" x 13" x 16" (27cm x 34cm x 41cm)
Shipping Weight	43 lbs. (19 kg)

**Nitrogen Flow and
Inlet Air Consumption
at Various Purities
and Pressures**

Operating Pressure		N ₂ Outlet Flow SLPM	Purity %N ₂	Inlet Air Required (1) SLPM
psig	barg			
125	8.6	6	99	45
125	8.6	24	95	70
90	6.2	4	99	30
90	6.2	16	95	45
60	4.1	2	99	20
60	4.1	10	95	30

1 Total air demand at full Nitrogen outlet flow.



All troubleshooting and service activities should be performed by suitable personnel using reasonable care.

Symptom - Nitrogen Generator	Course of Action
Loss of Outlet Pressure	Check that the flow control valve on the generator is fully open and control the flow with a valve at the process. Check operating pressure to assure that it is greater than 60 psig (4.1 barg). Check the system for leaks.
Loss of Outlet Flow	Check operating pressure to assure that it is greater than 60 psig (4.1 barg). Check setting of flow control valve. Adjust if necessary. Check the system for leaks.
Purity is Lower than Specified for Operating Conditions	Check setting of flow rate compared to specification. Check the operating pressure to assure that it has not varied from the original reading. Check the system for leaks. Measure the temperature and dewpoint of the inlet air. The recommended temperature is 68°F (20°C) and the recommended dewpoint 60°F (15°C) or lower. Calibrate oxygen analyzer (if needed).
Air Leak Through Drains of Prefilters	Check inlet pressure. It should be greater than 15 psig (1 barg) to seal drain. Remove tubing from the drain outlet, hold finger over drain opening for a few seconds to allow pressure to build and drain to seal. Remove bowl from filter assembly and rinse with water. If leak persists, replace automatic float drain (P/N 21552).

To arrange for system service, contact the Technical Services Department at 1-800-343-4048 or email at balstontechsupport@parker.com, 8AM to 5PM Eastern Time. For other locations outside North America, please contact your local representative.

Don't Forget To: Complete and mail your registration card.
Keep your product certification in a safe place.

Serial Numbers The serial number label for the unit is on the left side of the generator, below the inlet port. For your own records, and in case service is required, please record the following:

DATE IN SERVICE _____ SERIAL NO. _____

Parker Hannifin Corporation
Filtration and Separation Division
242 Neck Road, P.O. Box 8223
Haverhill, MA 01835-0723
Tel: 978-858-0505 Fax: 978-556-7501
www.labgasgenerators.com

Parker Filtration & Separation
Filtration Group Europe
Hermitage Court, Hermitage Lane
Maidstone, Kent ME16 9NT England
Tel: +44 (01622) 723300 Fax: +44 (01622) 728703
www.parker.com/pag



Member of

