

Dual-Column Direct Injection Tee

(Kit–cat.# 20412; Replacement Tee–cat.# 20411)

For use with dual 0.32 and 0.53mm ID fused silica capillary columns (tubing OD must be 0.4mm or greater). Fits Agilent, Varian, and most other GCs equipped with 1/4-inch on-column packed injection ports (4-inch maximum insertion depth).

Installation Instructions

1. Attach the 1/4-inch to 1/16-inch stainless steel reducing fitting onto both outlets of the Direct Injection Tee using the 1/4-inch graphite ferrule. Tighten the ferrule approximately 1/4-turn past finger-tight. Be careful not to place lateral torque against the glass liner or it could break.
2. Remove all internal pieces from the 1/4-inch injection port. (The injection port is now in the on-column mode.)
3. Insert the Direct Injection Tee (slotted end up) into the injection port and secure it with the 1/4-inch graphite ferrule and 1/4-inch SS nut provided in the installation kit. Allow a 1/16-inch gap between the top of the liner and the top of the injection port body. Tighten the ferrule approximately 1/4-turn past finger-tight or until the tee is held firmly.
4. Using a ceramic scoring wafer (cat.# 20116), cut approximately 6 inches off each column end while pointing the column end downward to prevent fused silica fragments from falling inside. Slide the 1/16-inch nut and a 0.5mm or 0.8mm ID graphite ferrule onto each column end. (Ferrule size depends on column OD.)
5. Cut an additional 3 inches off each column end making sure the cut is perfectly square. A square end can be achieved by scoring the tubing with a ceramic scoring wafer and flicking the column end away from the score. We do not recommend using diamond or tungsten carbide pointed scribes. Closely examine the column end with a magnifying glass (cat.# 20124) to make sure it is perfectly square. A poor cut results in a poor Press-Tight® seal and causes solvent tailing.

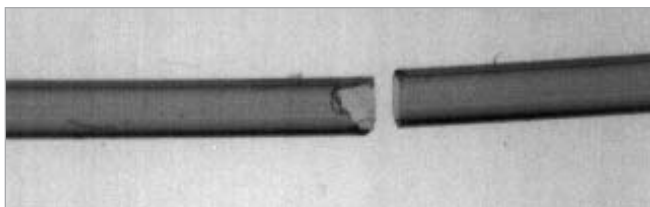

This photo demonstrates a bad and a good cut. The tubing must be cut squarely to obtain a correct seal in the Press-Tight® tapered region of the Dual Column Direct Injection Tee.

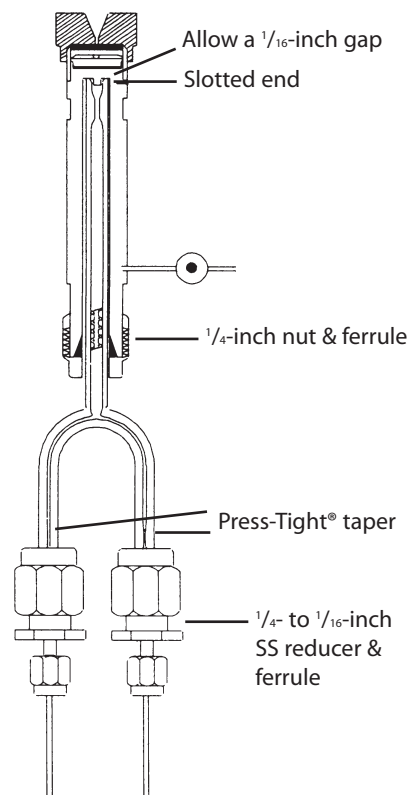

6. Next, seat the ferrule. **It is important to seat the ferrule before installing the column because, as a ferrule is compressed to fill the fitting cavity, it moves upward and crushes the column end.**

To seat the ferrule, insert the column end through the stainless steel reducer and gently position it so the column end is at least 1/2-inch below the Press-Tight® taper on the tee leg. Then tighten the 1/16-inch nut approximately 1/2-turn past finger-tight until the column end is held firmly and cannot be moved when gentle pressure is applied. The ferrule is now seated. Repeat this procedure for the second column.

7. Loosen the 1/16-inch nut and slowly push the column end into the Direct Injection Tee until it meets the Press-Tight® restriction. Retighten the nut and carefully examine the Press-Tight® taper region to make sure the upward movement caused by retightening the ferrule did not crush the column end. A uniform brown ring is visible if the column is connected correctly to the Press-Tight® taper. If there is powder or any deformation in the column end, then the column end is inserted too deeply into the taper. If this is the case, remove the column end from the reducing fitting, recut it, and try again. In cases where powder or glass

fragments are observed in the tapered region, remove the liner and blow out the fragments using compressed air or nitrogen. Repeat this procedure for the second column.

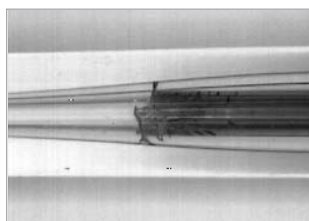

Improper installation

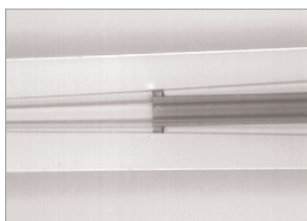

Proper installation

Note, fused silica shrapnel is pushed into the bore of the improperly installed column.

- Turn on the carrier gas (helium or hydrogen preferred) and set the column flow rate at approximately 10cc/min. (5cc/min. for each column). Use Restek's Leak Detector (cat.# 22839) to confirm a leak-tight connection. Do not use liquid leak detectors or contamination will occur.

Use methane or another nonretained substance to measure the dead time and linear velocity. See Table I for the recommended dead time for each column length and inside diameter. See the on-line column installation guide at www.restek.com/guide_cap.asp for column installation instructions and helpful hints.

Table I Dead volume times for both hydrogen and helium (80cm/sec.) carrier gases to achieve flow rates of approximately 5cc/min. for each column.

Column ID	Length			
	15-meter	30-meter	60-meter	105-meter
0.32mm	0.3 min.	0.6 min.	1.2 min.	2.1 min.
0.53mm	0.65 min.	1.3 min.	2.6 min.	4.5 min.

- Install the columns into the detector according to the GC manual. Make-up gas is required when operating the Dual Column Direct Injection Tee at 10cc/min.
- Perform the solvent peak shape test. An excessively tailing solvent peak indicates installation problems.

The solvent peak shape is a good indicator of system integrity.

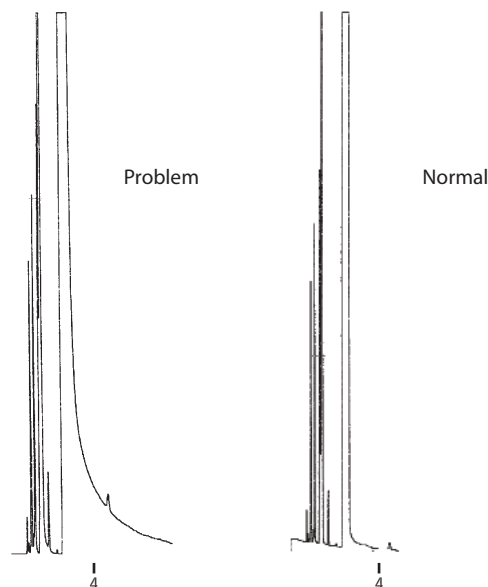

Rtx®-5, 30m, 0.32mm ID, 0.25µm
1.0µL split injection of methylene chloride

Oven temp.:	40°C isothermal	Linear velocity:	40cm/sec.
Inj. & det. temp.:	325°C	FID sensitivity:	4 x 10 ⁻¹¹ AFS
Carrier gas:	Hydrogen	Split ratio:	35:1

Call Technical Service at 800-356-1688 or 814-353-1300, ext. 4 (or your Restek representative) if you have any questions about this product or any other Restek product.

Restek trademarks: Press-Tight, Restek logo, Rtx



ISO 9001:2000 #205-09 [004]
cert.# FM80397 Rev: 07/2008

Restek U.S. • 110 Benner Circle • Bellefonte, PA 16823
phone: 814-353-1300 or 800-356-1688 • fax: 814-353-1309 • www.restek.com
Restek France • phone: 33 (0)1 60 78 32 10 • fax: 33 (0)1 60 78 70 90 • e-mail: restek@restekfrance.fr
Restek Ireland • phone: 44 2890 814576 • fax: 44 2890 814576 • e-mail: restekeurope@aol.com
Thames Restek U.K. LTD • phone: 44 1494 563377 • fax: 44 1494 564990 • e-mail: sales@thamesrestek.co.uk
Restek GmbH • phone: +49 (0) 6172 2797 0 • fax: +49 (0) 6172 2797 77 • e-mail: info@restekgmbh.de