

# Operating Hints for Using Split/Splitless Injectors



**Inside:**

*Overviews of split and splitless injection techniques*

*Backpressure-regulated injection systems*

*Headpressure-regulated injection systems*

*Operating in the split injection mode*

*Inlet liners for split injections*

*Operating in the splitless injection Mode*

*Inlet liners for splitless injections*

*Septum purge optimization*

*Problems associated with split and splitless injections*

*Direct injection as an alternative to splitless injection*

*Hints for analyzing dirty samples*

*Hints for performing routine injection port maintenance*

*Product listing*

## Table of Contents

<b>Overview of Split/Splitless Injection Techniques</b> .....	2
<b>Backpressure-Regulated Injection Systems</b> ..	2
<b>Headpressure-Regulated Injection Systems</b> .....	3
<b>Operating in the Split Injection Mode</b> .....	4
<b>Inlet Liners for Split Injectors</b> .....	6
<b>Operating in the Splitless Injection Mode</b> ..	7
<i>Solvent Focusing and Analyte Focusing</i> .....	9
<b>Inlet Liners for Splitless Injections</b> .....	11
<b>Septum Purge Optimization</b> .....	12
<b>Problems Associated with Split and Splitless Injections</b> .....	13
<i>Thermal Decomposition</i> .....	13
<i>Active Compounds</i> .....	13
<i>Molecular Weight Discrimination</i> .....	13
<i>Needle Discrimination</i> .....	14
<i>Backflash</i> .....	15
<i>Sample Size and Injection Port Temperature</i> .....	15
<i>Optimizing the Rate of Injection</i> .....	16
<i>Pressure Programming</i> .....	16
<b>Direct Injection as an Alternative to Splitless Injection</b> .....	16
<b>Hints for Analyzing Dirty Samples</b> .....	18
<b>Hints for Performing Routine Injection Port Maintenance</b> .....	19
<i>Cleaning and Deactivating Injector Liners</i> ..	19
<i>Replacing Critical Seals</i> .....	19
<i>Changing Septa</i> .....	19
<b>Product Listing</b> .....	4, 5, 9, 18, 19, 20–35
<i>Restek Flowmeter 6000</i> .....	4
<i>Soap Film Bubble Flowmeters</i> .....	4
<i>Split Vent Trap</i> .....	5
<i>Methane Cylinder</i> .....	5
<i>Split and Splitless Injection in Capillary GC, 4th Ed. book</i> .....	9
<i>Mini Wool Puller/Insertor</i> .....	18
<i>Nylon Tube Brushes and Pipe Cleaner</i> .....	19
<i>Leak Detective II Leak Detector</i> .....	19
<i>Siltek™ Inlet Liners</i> .....	20
<i>Base-Deactivated Inlet Liners</i> .....	20
<i>Prepacked Liners</i> .....	20
<i>Liners for Agilent/Finnigan GCs</i> .....	21–22
<i>O-rings</i> .....	23
<i>Inlet &amp; FID Maintenance Kits</i> .....	23
<i>VespeI® Ring Inlet Seals for Agilent 5890/6890 and 6850 GCs</i> .....	24
<i>Rethreading Tool</i> .....	24
<i>Replacement Inlet Seals</i> .....	25
<i>Replacement Inlet Cross-Disk Seal for Agilent GCs</i> .....	25
<i>Liners for Varian GCs</i> .....	26–27
<i>Varian Inlet Liner Seals</i> .....	27
<i>Inlet Liner Removal Tool</i> .....	27
<i>Liners for PerkinElmer GCs</i> .....	28
<i>Liners for Shimadzu GCs</i> .....	29
<i>Liners for Thermo Finnigan GCs</i> .....	30–31
<i>Inlet Liner Seal for TRACE™ 2000 GCs</i> .....	31
<i>Graphite Sealing Ring and Washer for 8000 Series and TRACE™ GC Inlet Liners</i> .....	31
<i>Septa</i> .....	32
<i>Press-Tight® Connectors</i> .....	33
<i>Polyimide Resin</i> .....	33
<i>MXT®-Union Connector Kits</i> .....	34
<i>Valco® Connectors</i> .....	34
<i>Gerstel GRAPHPACK® 3D/2 Connectors</i> .....	34
<i>Guard Columns and Transfer Lines</i> .....	35

## Overview of Split/Splitless Injection Techniques

In capillary and micropacked gas chromatography (GC) there are four primary techniques for vaporizing a sample and transferring it onto the inlet of the analytical column: split, splitless, direct, and on-column injections. Of these, split and splitless injections are the most commonly used techniques. This technical guide focuses on split and splitless injections—their optimization, troubleshooting, and system maintenance.

Split and splitless injections are techniques that introduce the sample into a heated injection port as a liquid, and then rapidly and completely vaporize the sample solvent as well as all of the analytes in the sample. The vaporized sample is transferred to the head of the column.

In the split injection mode, only a fraction of the vaporized sample is transferred onto the head of the column. The remainder of the vaporized sample is removed from the injection port via the split vent line. Split injections should be used only when sample concentrations are high enough to allow a portion of the sample to be discarded during the injection process, while still maintaining a sufficient concentration of analytes at the detector to produce a signal.

When target analyte concentrations are so low that splitting the sample in the injection port will not allow an adequate signal from the detector, the injector should be operated in the splitless injection mode. In the splitless injection mode, most of the vaporized sample is transferred to the head of the column.

The process of performing either a split or splitless injection is controlled by changing the flow path and flow rate of carrier gas through the injection port. The position of a switching valve in the injection port determines the flow path. In split injections, a high carrier gas flow rate rapidly moves the vaporized sample through the injection port liner, past the column (with only a minimal amount directed to the head of the column), and out the split vent. In splitless injections, a relatively slow carrier gas flow rate directs most of the vaporized sample into the head of the column.

Split/splitless injection ports can be either backpressure-regulated or headpressure-regulated systems. Most modern GCs are backpressure regulated. However, some GC manufacturers still find headpressure regulation advantageous and use this design in their split/splitless injectors. It is important for analysts to be familiar with their injection port hardware and the operating principles of their instruments, so that they factor in the variables affecting the accuracy and reproducibility of their results.

## Backpressure-Regulated Injection Systems

Figure 1 illustrates the components of a typical backpressure-regulated split/splitless injection system (e.g., Agilent 5890, 6850, 6890 GCs; Varian 3300, 3400, 3500, 3600, 3800 GCs; Shimadzu 17A GCs). A flow controller, positioned upstream from the injection port, controls the total amount of carrier gas that enters the injection port. A backpressure regulator, located downstream from the injection port body, regulates the pressure inside the injection port. Carrier gas flow rate in the column is determined by the pressure that is maintained in the injection port. The outlet of the backpressure regulator is the outlet of the split vent line. The split vent line outlet is at the ambient pressure of the laboratory. The flow controller and the backpressure regulator work together to determine the column flow rate, septum purge flow rate, and split vent flow rate.

Split and splitless injections in backpressure-regulated systems are controlled by the position of the 3-way solenoid valve. In the split injection mode, the flow path is always open from the injection port body through the 3-way solenoid valve to the split vent line. In the splitless injection mode, the flow path is temporarily closed from the injection port body to the split vent line. The carrier gas flow rate through the injection port liner is simply the column flow rate. Any excess flow is directed through the septum purge line, into the 3-way solenoid valve, and out the split vent line.

In backpressure-regulated systems, the split vent flow rate is changed by adjusting the flow controller. An increase in the total flow being delivered to the injection port will result in a higher split vent flow rate and a higher split ratio. Column flow rate is not affected by changes in the total flow being delivered to the injection port, but by the backpressure regulator. To maintain the same pressure at all times, use the backpressure regulator to compensate for a change in the total flow delivered to the injection port.

A flow-controlled, backpressure-regulated system is beneficial as it gives some measure of protection against a catastrophic loss of carrier gas. If there is a leak at an injection port fitting or a column fitting, the maximum rate of carrier gas loss would be the total flow rate into the injection port as determined by the flow controller. Unlimited flow of carrier gas into the injection port is prevented by having the flow controller at the inlet of the injection port. Leaks are indicated by a failure to maintain split vent flow rate. A common mistake analysts make when they observe a reduced split vent flow is to increase the total system flow, rather than check for leaks at the injector and column fittings. By understanding the characteristics of backpressure regulated pneumatics, analysts can detect and correct a leak, to avoid poor chromatography.

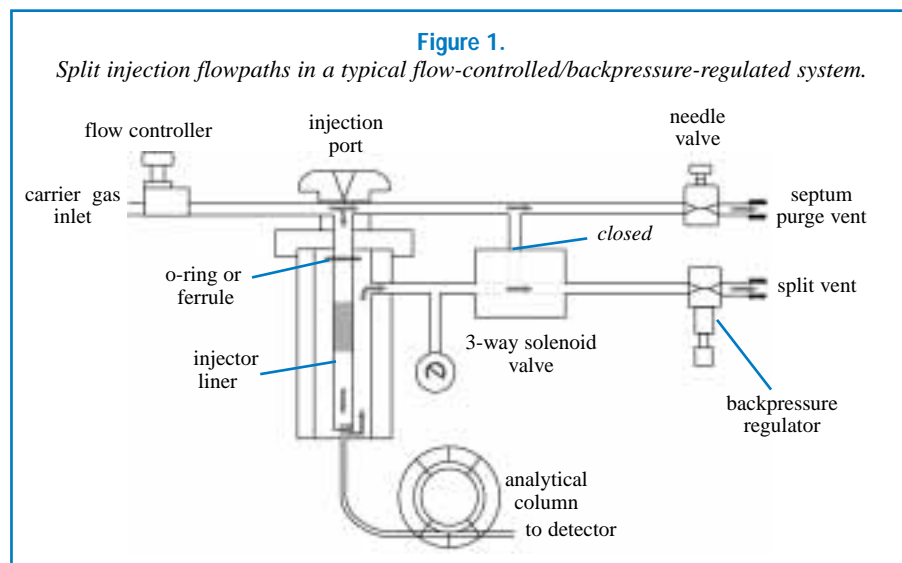
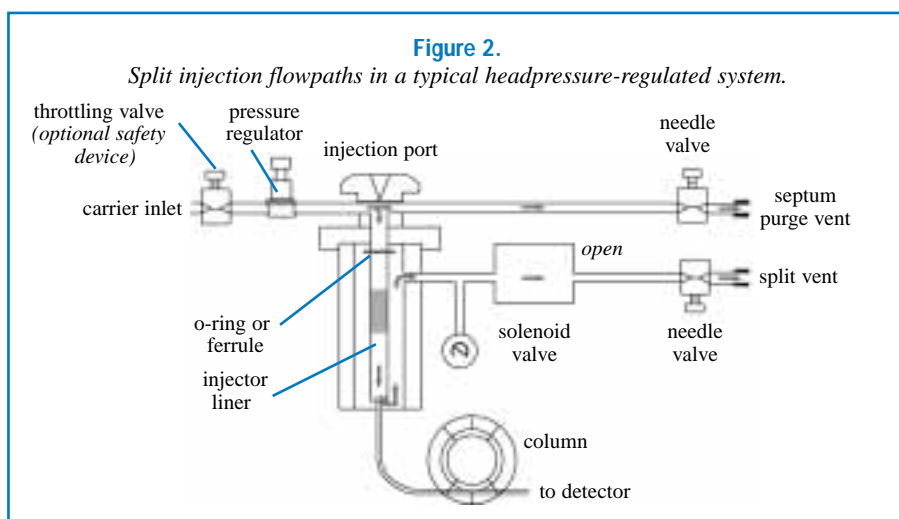

**Figure 1.**

- All carrier gas except septum purge flow directed through injector.
- Column flow (established by backpressure regulator) enters column.
- Solenoid valve open from injector to split vent. Bulk of gas flows out of injector liner, through solenoid valve, out split vent.
- Sample vapor is directed onto column or vented through split vent and is split in the same proportions as for carrier gas.
- Split ratio = portion of sample vented from split vent/portion of sample that enters column.

## Headpressure-Regulated Injection Systems

Figure 2 illustrates the components of a typical headpressure-regulated split/splitless injection system (e.g., PE Autosystem; Shimadzu 9A & 14A; Thermo Finnigan Trace 2000 GCs). A pressure regulator upstream from the injection port regulates or maintains the pressure inside the injection port. The pressure regulator supplies an unlimited flow of carrier gas until the desired pressure is reached. The pressure inside the injection port establishes the carrier gas flow in the column and determines the column flow rate. Flows through the split vent line and the septum purge line are controlled by needle valves or restrictors downstream from the injection port. The outlet pressure of the septum purge and split vent lines is ambient pressure. As long as constant pressure is maintained in the injection port, needle valves and restrictors will give constant flows.



**Figure 2.**

- Solenoid valve open: column flow passes into column, split flow exits through split vent.
- Throttling valve guards against loss of carrier gas caused by leaks in injection system.

## Restek Flowmeter 6000



- Calculates linear velocity based on column ID.
- Useful for measuring flows for N<sub>2</sub>, air, He, H<sub>2</sub>, CO<sub>2</sub>, O<sub>2</sub>, Ar, 7.5% CH<sub>4</sub>/Ar.
- Reads flow accurately from 0 to 500mL/min. (0–300mL/min. for CO<sub>2</sub>).
- Accuracy is 0.2mL/min. or +/- 2.5%.
- Usable with inlet pressures up to 25psi.
- Measures split flow and calculates split ratio.
- Automatic shut-off.



Description	qty.	cat.#
Restek Flowmeter 6000 (9-volt battery-operated)	ea.	21622
Recalibration Service for Restek Flowmeter 6000	ea.	24618

## Soap Film Bubble Flowmeters

- 1mL flowmeter measures flows between 0.1 and 10cc/min.
- 50mL flowmeter designed for flows between 10 and 300cc/min.
- Both flowmeters come with a reservoir bulb, twenty-four inches of 1/4-inch ID tubing, adaptor tubes for 1/8-inch tubing and 0.53mm ID capillary columns, and Velcro® fasteners.



Description	qty.	cat.#
1mL Bubble Flowmeter	ea.	20135
50mL Bubble Flowmeter	ea.	20136

An on/off solenoid valve is used in headpressure-regulated systems instead of the 3-way solenoid valve used in backpressure-regulated systems. The position of the solenoid valve determines whether the injection port is operated in the split or splitless injection mode. In the split injection mode, the solenoid valve is always in the open position and the carrier gas is allowed to flow through the injection port liner and out the split vent line. In the splitless injection mode, the solenoid valve is closed and the only flow through the injection port liner is the column flow. The pressure regulator compensates for excess carrier gas flow available when the solenoid valve closes.

The throttling valve upstream from the pressure regulator (Figure 2) is an optional component not typically included by the chromatograph manufacturer. We recommend installing a throttling valve (flow controller or needle valve) to guard against catastrophic loss of carrier gas if a leak occurs at an injection port fitting or a column fitting. To adjust the throttling valve, gradually close the valve, reducing the gas flow until it matches the requirements of the injection system. When the column headpressure begins to decrease, the throttling valve is closed too far.

## Operating in the Split Injection Mode

When operating in the split injection mode (Figures 1 and 2), the solenoid valve is always open along the flowpath from the injection port body to the split vent. With the exception of the septum purge flow, all of the carrier gas entering the injection port flows through the injection port liner and toward the head of the column. At the head of the column, the carrier gas flow is split between two flow paths: a portion of the flow enters the column as the column flow rate, and the remaining carrier gas flow is allowed to escape from the injection port, out the split vent line via the solenoid valve. The amount of flow entering the column is determined by the pressure of the carrier gas inside the injection port and the dimensions of the analytical column. The relative proportions of the split vent flow and the column flow determine the split vent ratio.

Samples completely vaporized in the injection port liner behave in the same fashion as the carrier gas; sample vapors are split in the same proportions as the carrier gas, thereby allowing only a fraction of the sample to be introduced into the head of the column. A 50-to-1 split ratio can be used as a starting point when developing split injection methods. Table I shows the appropriate split vent flow rates for helium and hydrogen carrier gases when using common capillary column IDs.

**Table I.**

*Typical split vent flow rates for 50-to-1 split ratio at optimum linear velocity when using a 30-meter column at 40°C.*

Carrier Gas	Column ID (mm)/Split Vent Flow Rate			
	0.18	0.25	0.32	0.53
helium*	25cc/min.	37.5cc/min.	55cc/min.	135cc/min.
hydrogen**	50cc/min.	75cc/min.	110cc/min.	270cc/min.

\*optimum carrier gas linear velocity=20cm/sec.

\*\*optimum carrier gas linear velocity=40cm/sec.

Equation 1 shows how the split ratio is calculated. Split vent flow rates easily can be measured using a standard electronic flowmeter (cat.# 21622). However, measuring low flow rates (from 0.3 to 5cc/min.) exiting a capillary column can be difficult unless a special low-volume bubblemeter (cat.# 20135) or a sensitive electronic flowmeter is used. If a low flow-measuring device is not available, Equation 2 can be used to determine the approximate column flow.

Calculating the on-column concentration of analytes is necessary to ensure that the column is not overloaded and is operating within its capacity limits. Although quantitative analysis does not require that the on-column concentration be known, exceeding column capacity decreases resolution and reduces quantitative accuracy. Equation 3 illustrates how to calculate the approximate on-column concentration in the split mode.

Setting the injection port temperature properly is critical for obtaining good peak shape and response. Injection port temperature must be hot enough to provide rapid vaporization of all

**Equation 1.***Calculating the split ratio.*

$$\text{Split ratio} = \frac{\text{column flow} + \text{split vent flow}}{\text{column flow}}$$

**Equation 2.***Calculating the approximate column flow rate.*

$$\text{Flow} = \frac{(\pi) (\text{column radius in cm})^2 (\text{column length in cm})}{\text{dead volume time (min.)}}$$

where  $\pi = 3.14159$ 

For example, a 30m x 0.53mm ID column operated at 20cm/sec. linear velocity (helium) retains methane for 2.50 min., and therefore has a flow rate of 2.65cm<sup>3</sup>/min.:

$$\text{Flow} = \frac{(3.14159) (0.0265\text{cm})^2 (3000\text{cm})}{2.50 \text{ min.}} = 2.65\text{cm}^3/\text{min.}$$

**Equation 3.***Calculating the approximate on-column concentration for split injections.*

$$\text{Concentration} = \frac{\text{concentration in sample } (\mu\text{g}/\mu\text{L}) \times \text{sample vol. injected } (\mu\text{L})}{\text{split ratio}}$$

sample components. In the split injection mode, the residence time of the sample in the injection port is very short because of the high carrier gas flow rate through the injection port liner and out the split vent. As a result, vaporization must be completed as rapidly as possible. However, injection port temperatures must not be so high that they cause sample degradation.

When set up properly, split injections are very reproducible. Samples introduced under constant temperature, pressure, and flow conditions will vaporize and split consistently.

Split injections can be used for both qualitative and quantitative work. Internal or external reference compounds are split under identical conditions compared to analytes in samples. Any variations experienced by the sample also are experienced by the reference compounds when the sample matrix and standard matrix match exactly. In general, split inlet liners are designed to have added surface area to help with sample vaporization. Improved vaporization can be achieved with changes in liner geometry that increase the surface area. Examples include incorporating fused silica or glass wool, CarboFrit™ packing, or using a laminar cup.

**Caution!**

When analyzing hazardous compounds in the split mode, make sure they do not enter the lab atmosphere through the split vent. A small, charcoal-filled split vent trap connected to the split vent protects you from breathing contaminated air (cat. # 20698).

**High-Capacity Split Vent Trap**

- Reduces the release of hazardous materials from the capillary split vent into the lab.
- Lasts one month or 1,500 injections.
- Includes connecting lines and mounting kit.



Description	qty.	cat. #
High-Capacity Split Vent Trap	ea.	20698
High-Capacity Split Vent Trap	5-pk.	20699

For customer service, call  
**800-356-1688, ext. 3**  
 (814-353-1300, ext. 3)  
 or call your local  
 Restek representative.

**Methane Cylinder**

Setting the column flow rate by injecting methane and optimizing linear velocity is a preferred method for establishing reproducible retention times (ASTM Method E1510-93). Measuring the linear velocity of your carrier gas is made easy by using the Scotty® 14 cylinder containing 1% methane in helium. The complete kit includes the Scotty® 14 cylinder, a MINICYL regulator, a syringe adaptor, and a package of twenty septa for the adaptor.

Description	qty.	cat. #
Complete Kit	kit	20197
Replacement Septa	20-pk.	20198
Replacement Cylinder	ea.	20199

## Inlet Liners for Split Injections

Split liners are designed with mixing chambers and tortuous flow paths, to fully vaporize the sample into a homogeneous vapor cloud before it reaches the split point. All Restek split liners are fully deactivated using a high-temperature silanizing reagent. This caps surface silanol groups so active compounds in the sample do not degrade or adsorb onto the hot glass surface.

To trap non-volatile residue and prevent column contamination when analyzing dirty samples, pack split liners with wool, CarboFrit™ packing, or fused silica beads. Some of the more commonly used inlet liners are described below.

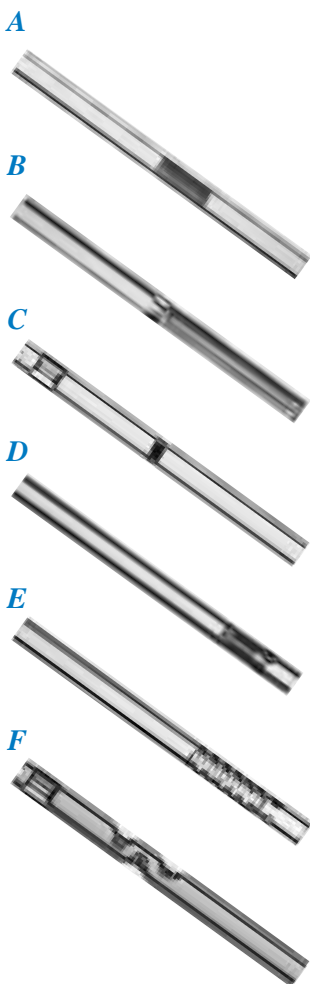

### A) Split Liner with Wool

The wool provides a large surface area to allow rapid vaporization of the sample and deliver a uniform vapor cloud to the split point. The low mass of the wool fiber promotes complete vaporization.

**Benefits:**

- Low cost.
- Reproducible performance.

**Drawbacks:**

- Wool can be adsorptive, especially if fibers are broken.
- High maintenance requirements.

### B) Laminar Cup Splitter

The sample flows through a small opening and encounters the head of the elongated glass cup. It then travels around the outside of the elongated cup before the flow is inverted twice. Larger volume injections are possible because the liquid is trapped at the inner base and cannot escape until vaporized.

**Benefits:**

- Recommended by chromatography expert Dr. Konrad Grob<sup>1</sup>.
- Best splitter liner for high molecular weight compounds.
- Laminar flow profile provides highest resolution.

**Drawbacks:**

- Costly.

### C) Frit Splitter

The sample must pass through the porous ceramic frit. The high surface area and tortuous flow path ensure complete vaporization.

**Benefits:**

- Traps septum particles and residue.

**Drawbacks:**

- Ceramic frit can be active.
- Difficult to clean.

### D) Cup Splitter

The sample flows through a mini funnel and encounters a glass cup. The flow path then inverts twice before reaching the split point.

**Benefits:**

- Tortuous flow path aids in sample vaporization.
- Minimizes molecular weight discrimination.
- Can be packed with wool to trap particles.

**Drawbacks:**

- Difficult to clean.

### E) Cycloplitter® (Patent #: 5,119,669)

This patented design incorporates a cylindrical glass spiral in the sample pathway, providing a large area for sample vaporization.

**Benefits:**

- Ideal for dirty samples.
- Allows many injections of dirty samples before cleaning is required.
- Easy to clean.

**Drawbacks:**

- Not recommended for large volume injections.

### F) Baffle Splitter

The baffle induces turbulent flow that directs the sample against the wall of the glass liner.

**Benefits:**

- Reproducible performance.

**Drawbacks:**

- Prone to molecular weight discrimination.
- Septum particles and residue can enter column.
- Subject to incomplete vaporization.

all liners are  
**100%**  
deactivated

See page 17.

All Restek liners are deactivated to prevent adsorption of active compounds. Call for information on custom deactivations.

<sup>1</sup>"Injectors Providing Complete Sample Evaporation Above the Column Entrance in Vaporizing GC Injections," K. Grob and C. Wagner, *HRC & CC*, Vol. 16, p. 429.

## Operating in the Splitless Injection Mode

When operating in the splitless injection mode (Figures 3 and 4), the solenoid valve is switched, changing the flow path of the carrier gas. At the beginning of a splitless injection, the solenoid valve is set to prevent the flow of carrier gas from the injection port body through the solenoid valve. When the solenoid valve is in this position, only the column flow moves through the injection port liner. Column flow rate is determined by the pressure of the carrier gas in the injection port as set by the pressure regulator and the analytical column dimensions.

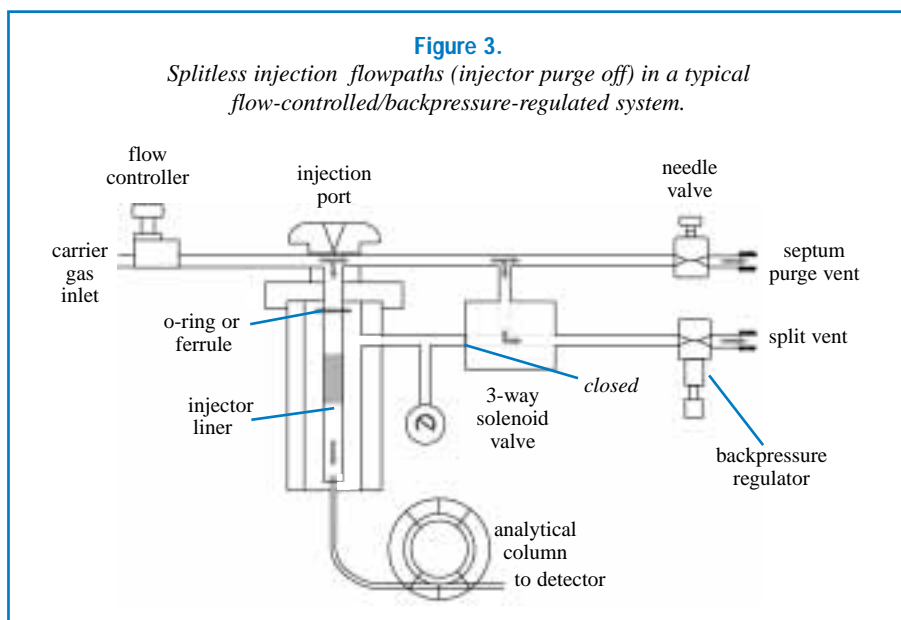

**Figure 3.**

- Solenoid valve closed between injector and split vent: only column flow enters injector; column flow passes into column.
- Needle valve at septum purge vent allows only septum purge flow to exit septum purge vent: most of carrier gas diverted through solenoid valve, out through split vent.
- Sample vapor in injector liner can exit only to column, mixed with column flow of carrier gas.
- Solenoid valve switched to establish flowpaths as in split injection: sample vapor remaining in injection port swept out of split vent.
- Splitless hold time determined by sample composition.

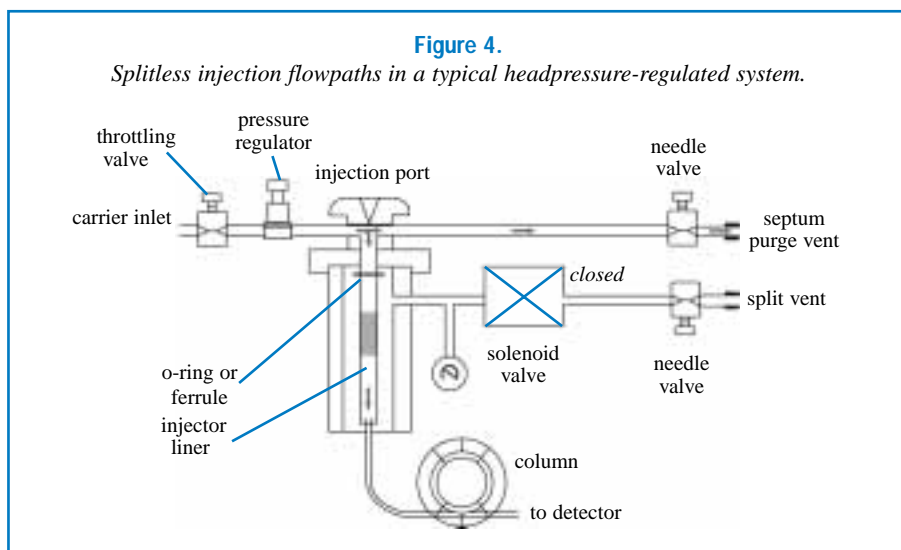

**Figure 4.**

- Solenoid valve closed: entire carrier gas flow and entire sample directed onto analytical column.
- Carrier gas flow rate into system reduced to enable entire flow to pass through analytical column.

After a carefully determined time (the splitless hold time) the solenoid valve is switched to re-establish the flow paths as used in the split injection mode. This allows any vaporized sample remaining in the injection port to be quickly swept out of the injection port liner through the split vent. A typical splitless hold time is between 60 and 90 seconds. The ideal splitless hold time is long enough to allow most of the vaporized sample in the injection port liner to be transferred to the analytical column. Excessively long splitless hold times can produce tailing peaks and broad peaks. The splitless hold time must be determined through experimentation, and will vary according to sample composition, column length and

**Table II.** Typical splitless hold times.

Column ID	Hold Time	Column Flow Rate		Sample Transfer Time*	
		He	H <sub>2</sub>	He	H <sub>2</sub>
0.18mm	2 min.	0.3cc/min.	0.6cc/min.	2.7 min.	1.4 min.
0.25mm	1 min.	0.7cc/min.	1.4cc/min.	1.2 min.	0.6 min.
0.32mm	0.75 min.	1.2cc/min.	2.4cc/min.	0.7 min.	0.4 min.
0.53mm	0.5 min.	2.6cc/min.	5.2cc/min.	0.3 min.	0.2 min.

\*2 $\mu$ L of liquid methylene chloride expanded to 0.8mL vapor at 250°C (10psig headpressure).

ID, carrier gas flow rate, and injection port liner configuration. Table II lists approximate splitless hold times for various column IDs when operated with helium or hydrogen. The splitless hold time will decrease as either the column ID or column flow rate increases.

Setting an optimal splitless hold time also is dependent on the choice of sample solvent and the sample size. Use Table III to estimate the volume of vapor produced when using different solvents at different pressures. The volume of vapor cloud formed should be divided by the column flow rate to determine the approximate time needed to keep the solenoid valve closed for complete sample transfer. The calculated splitless hold time also should be evaluated to provide the optimum response for the sample analytes. If the solenoid valve is

**Table III.** Solvent expansion volumes.

Solvent	Density (g/mL)	MW	Expansion Volume in $\mu$ L at various column headpressures		
			5psig	10psig	15psig
Heptane	0.68	100	219	174	145
Hexane	0.66	86	245	196	163
Pentane	0.63	72	280	224	186
Toluene	0.87	92	303	242	201
Ethyl acetate	0.90	88	328	261	217
Chloroform	1.49	119	400	319	266
Methylene chloride	1.33	85	500	399	332
Methanol	0.79	32	792	629	525
H <sub>2</sub> O	1.00	18	1776	1418	1179

The expansion volumes were determined using a 1.0 $\mu$ L injection volume, a 250° C injection port temperature, and a headpressure of 5, 10, or 15psig (common operating pressures for 30m columns having IDs of 0.53, 0.32, or 0.25mm, respectively). For 2 $\mu$ L injections, double the expansion volumes.

**Use these formulas to calculate values not listed in Table III:**

$$\text{Expansion volume} = nRT / P$$

n = number of moles of solvent and sample.

$$= [\text{volume (mL)} \times \text{density (g/mL)}] / \text{mol. wt. (g/mole)}$$

R = gas law constant

$$= 82.06\text{cc atm/mole } ^\circ\text{K}$$

T = absolute temperature of injector (°K)

$$(^{\circ}\text{K} = ^{\circ}\text{C} + 273)$$

P = absolute column headpressure = gauge pressure (atm) + 1 atm

$$\text{atm} = \text{psig} \times 0.06804 \text{ atm / psig}$$

injector liner volume\* =  $\pi r^2 L$

$$\pi = 3.14$$

r = liner internal radius (cm)

L = liner length (cm)

\*Also use this formula to determine capillary column internal volume.

For customer service, call  
**800-356-1688, ext. 3**  
 (814-353-1300, ext. 3)  
 or call your local  
 Restek representative.

opened too quickly, responses will be low. However, if the solenoid valve remains closed too long, the solvent peak will tail and peak resolution will suffer. To help determine the optimal splitless hold time, a series of injections should be made using increasingly longer splitless hold times. When the response for the analytes of interest plateaus, the sample transfer process has been optimized (Figure 5).

Setting the injection port temperature for splitless injections is critical, just as it is for split injections. The injection port temperature must be high enough to completely vaporize the sample, yet not so high that it causes sample degradation. This is especially important because the residence time for a sample in the injection port during splitless injections is longer, compared to split injections.

#### **Solvent Focusing and Analyte Focusing**

The long residence time for samples in the injection port also affects peak shape. In splitless injections, samples are transferred to the head of the column over a longer period of time than in split injections. As a result, initial peak bandwidths can be very broad unless vaporized samples are refocused at the head of the column. Two techniques can be used to refocus vaporized samples at the head of the column: solvent focusing and analyte focusing. The difference between the two methods is the initial temperature of the column oven. For solvent focusing, the initial oven temperature is low enough to allow the solvent to recondense at the head of the column. This forms a zone of liquid solvent that traps all of the vaporized sample analytes in a narrow band at the head of the column. Analyte focusing requires an initial oven temperature that allows the solvent to move through the column as a vapor immediately after injection. Analytes that have a significantly higher boiling point than the solvent are recondensed at the head of the column because of the lower oven temperature.

A typical sequence of events for performing a splitless injection using solvent focusing is as follows:

1. Set the initial oven temperature approximately 20°C below the boiling point of the sample solvent.
2. Close the solenoid valve to divert the entire sample onto the head of the column.
3. Inject the sample and hold the oven temperature at the initial temperature to recondense the solvent and focus the sample at the head of the column. The initial oven temperature is typically held for the same amount of time that the solenoid valve is closed.
4. Switch the solenoid valve to open the flow path to the split vent line and rapidly program the oven temperature (10 to 30°C/min.) until the first analyte of interest elutes.
5. Slow the oven program rate to enhance resolution of the remaining analytes of interest.

**Figure 5.**

*Optimization of splitless hold time.*

The splitless hold time is optimized when further increases do not increase analyte response but result in solvent tailing.

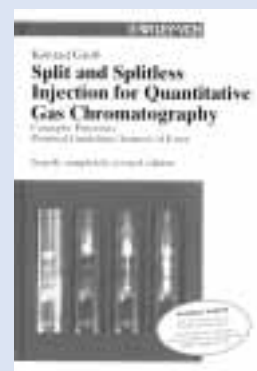
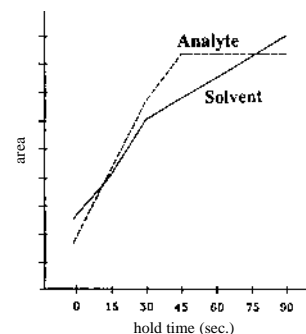

#### **Split and Splitless Injection in Capillary GC, 4th Ed.**

This comprehensive handbook of split and splitless injection techniques has been totally revised and updated, containing information on sample evaporation in the injector, matrix effects, and a new chapter on injector design. It also includes a CD-ROM containing visualization of the evaporation process during split and splitless injection.

*K. Grob, Wiley-VCH, 2001, 460pp., ISBN 3-527-29879-7 cat.# 20451 (ea.)*

**Figure 6.**

*Initial oven temperature too high for improper solvent focusing: solvent peak and early eluting compounds are tailing.*

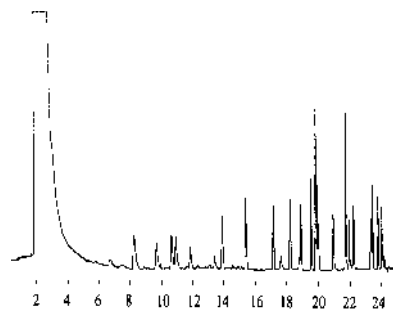

30m, 0.25mm ID, 0.25 $\mu$ m Rtx<sup>®</sup>-5 (cat.# 10223)  
1.0 $\mu$ L splitless injection of a pesticide mix in  
hexane (5ng/ $\mu$ L);  
**Oven temp.:** 150°C to 275°C @ 4°C/min.

**Figure 7.**

*Initial oven temperature at least 20°C below boiling point of earliest eluting analyte: early eluting compounds are symmetrical.*

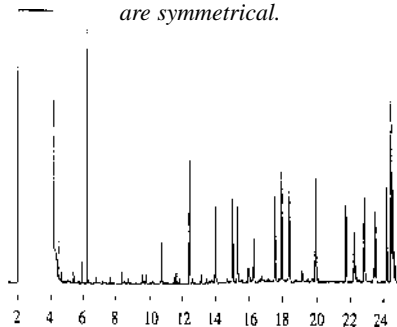

30m, 0.25mm ID, 0.25 $\mu$ m Rtx<sup>®</sup>-5 (cat.# 10223)  
1.0 $\mu$ L splitless injection of a pesticide mix in  
hexane (5ng/ $\mu$ L); **Oven temp.:** 40°C to 150°C  
@ 25°C/min. then to 275°C @ 4°C/min.

The sequence of events for analyte focusing is the same, except for the initial oven temperature; instead of starting 20°C below the boiling point of the solvent, the oven temperature is started 60–80°C below the boiling point of the earliest eluting compound.

Figure 6 shows an example of improper solvent focusing. The sample solvent is hexane, which has a boiling point of 69°C. The initial oven temperature is 150°C, or 80°C above the boiling point of hexane. The solvent peak is tailing, and the early-eluting compounds have broad peak shapes and are poorly resolved from one another. Figure 7 illustrates proper solvent focusing. The initial oven temperature, 40°C, is well below the boiling point of hexane. The square solvent peak is a good indicator of proper solvent focusing. Also notice the sharp peak shapes for both early- and late-eluting compounds. When the solvent is not detected or elicits a low response, such as hexane with electron capture detectors (ECDs), the only indication of proper solvent focusing is narrow peaks for early-eluting compounds.

For optimal solvent focusing, choose a solvent that has a boiling point at least 20°C below the boiling point of the earliest eluting target analyte. In some cases, it is not possible to select the perfect solvent to achieve focusing. For example, methylene chloride (boiling point 40°C) is frequently used for splitless work because of sample preparation techniques. Analyses performed with an initial oven temperature of 40°C will not allow the solvent to recondense at the head of the column and will not refocus the sample analytes. Ideally, analysts would start the oven temperature at 20°C when using methylene chloride as the sample solvent, but because this is not practical, they must rely more on analyte focusing to refocus sample analytes at the head of the column.

An important part of solvent focusing is the ability of the solvent to “wet” the stationary phase in the column. Non-polar solvents should be used for splitless injections on non-polar stationary phases (e.g., use hexane or isooctane for injections on Rtx<sup>®</sup>-1 and Rtx<sup>®</sup>-5 columns). Non-polar solvents are more soluble in non-polar stationary phases and will form a more efficient zone of recondensed solvent in the column. Polar solvents are not as soluble in non-polar stationary phases and will bead up on the stationary phase rather than forming an even layer of recondensed solvent at the head of the column. Mismatches between the polarity of the solvent and the polarity of the stationary phase can cause band broadening, peak splitting, and poor resolution.

Once again, the same basic procedures are followed for analyte focusing, except the initial oven temperature is 60–80°C below the boiling point of the earliest eluting compound, instead of 20°C below the boiling point of the solvent, as with solvent focusing.

A unique situation with Agilent 5890 and 6890/6850 split/splitless inlets makes a double gooseneck liner highly desirable for samples that contain compounds prone to catalytic degradation through contact with hot metal surfaces. Agilent splitless inlets contain a metal seal at the base of the inlet (just under the liner outlet). Because the column is installed only a few millimeters above the seal surface, the sample contacts the seal while it is being slowly drawn into the column. A double gooseneck inlet liner minimizes contact between the sample and the metal seal. A dirty seal increases the breakdown of endrin (a pesticide prone to decomposition) from 6% to 12.8% in an Agilent 5890 inlet when a 4mm straight inlet liner is installed. However, when a double gooseneck inlet liner is used, the breakdown remains at 2% regardless of whether the seal is clean or dirty. (For more information, see page 24 of this guide for a description of our Vespel<sup>®</sup> Ring Inlet Seal.)

*Double gooseneck inlet liner minimizes the catalytic effects of sample contact with the metal disk in an Agilent inlet.*

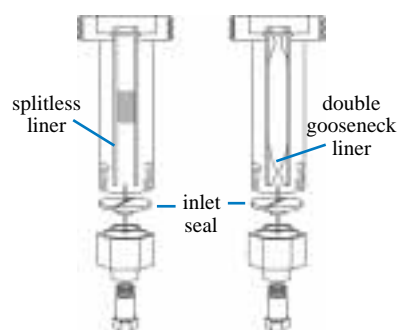

Liner Type	Endrin Breakdown	
	Clean Seal	Dirty Seal
Splitless with Wool	6.0%	12.8%
Double Gooseneck	2.0%	2.4%

## Inlet Liners for Splitless Injections

The residence time of the sample in a splitless liner is between 0.5 and 2 minutes, so splitless inlet liners do not require large surface areas for efficient vaporization (unless you are using a rapid-injecting autosampler). Splitless liners usually are designed as straight tubes. Alternative splitless liner designs, such as gooseneck restrictions, help contain the sample cloud in the injector and minimize the breakdown of compounds sensitive to catalytic decomposition on metal inlet parts. Splitless liners should be packed with wool or fused silica beads to help with vaporization, trap non-volatile residue, and prevent column contamination when analyzing dirty samples. Some of the more commonly used splitless liners are described below.

### A) Straight Tube

Use for samples containing a narrow molecular weight distribution and for those not prone to thermal decomposition. Packing with wool is recommended. Wool aids in vaporization of high molecular weight compounds and minimizes discrimination.

#### Benefits:

- Low cost.

#### Drawbacks:

- Potential decomposition of active compounds such as endrin and phenols when packed with wool.
- Prone to high molecular weight discrimination.
- Sample exposed to metal surface below liner.

### B) Gooseneck

#### C) Recessed Gooseneck

##### Benefits:

- Increases splitless efficiency.
- Decreases breakdown of active compounds such as endrin and DDT.
- Chamber contains sample vaporization cloud.
- Can be packed with wool.

##### Drawbacks:

- No known drawbacks.

### D) Double Gooseneck

#### E) Recessed Double Gooseneck

Best liner for catalytically labile or high molecular weight compounds. Isolates sample from metal injection port parts. Use the cyclo-version for dirty samples.

##### Benefits:

- Highest splitless efficiency.
- Breakdown of active compounds decreased.
- Chamber contains vaporization cloud.

##### Drawbacks:

- Higher cost than straight splitless liners.
- Only recessed double goosenecks can be packed with wool.

*Note: Recessed gooseneck liners offer the same benefits as single or double gooseneck liners, but the base of the recessed gooseneck can be packed with wool and the liner can be used for dual-column analysis with a two-hole ferrule.*

### F) Drilled Uniliner®

This direct injection liner features a hole drilled into the inlet end that reduces sample discrimination, compared to typical splitless injections.

#### Benefits:

- Excellent transfer of analytes to column.
- Decreases injection port discrimination.
- Removes excess solvent vapor.
- Eliminates the need for wool.
- No sample contact with metal parts below liner, less adsorption.

#### Drawbacks:

- Higher amounts of non-volatile materials transferred to column.

### G) 4mm Splitless with Fused Silica Wool

The wool provides a large surface area to allow rapid vaporization of the sample and deliver a uniform vapor cloud to the split point. The low mass of the wool fiber promotes complete vaporization.

#### Benefits:

- Low cost.
  - Reproducible performance.
- #### Drawbacks:
- Wool can be adsorptive, especially if fibers are broken.
  - High maintenance requirements.

all liners are  
**100%**  
deactivated

See page 17.

All Restek liners are deactivated to prevent adsorption of active compounds. Call for information on custom deactivations.

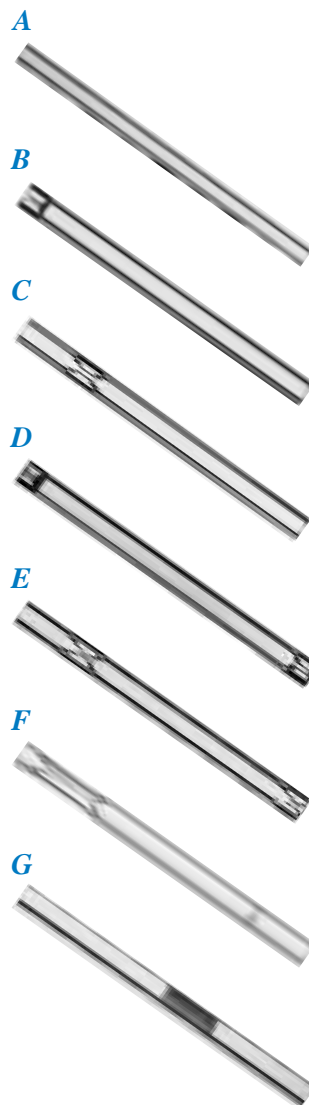

## Septum Purge Optimization

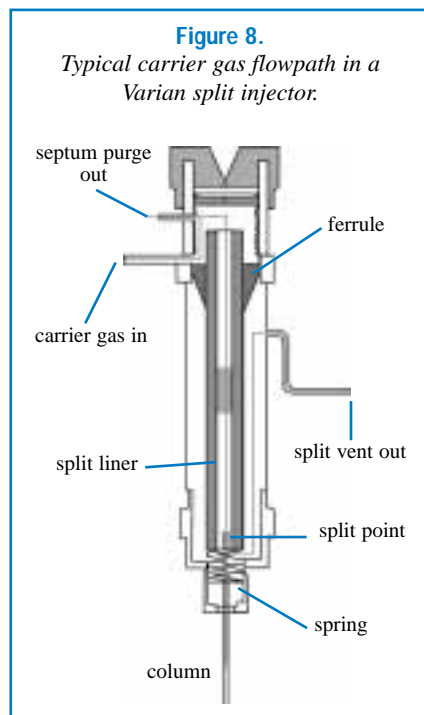

The septum purge (Figure 8) serves two functions: to sweep septum bleed volatiles out of the system and to reduce the potential for sample backflash contaminating the carrier gas inlet line. Optimization of the septum purge flow rate is important, especially when the inlet is operated in the splitless mode. Most GC manufacturers recommend that the septum purge flow rate be set between 3 and 5cc/min. Flow rates exceeding 5cc/min. should not be used because highly volatile sample components could be preferentially purged from the inlet liner buffer volume after vaporization. Flow rates lower than 3cc/min. can allow septum bleed to enter the inlet liner and cause ghost peaks to appear on the chromatogram.

The septum purge flow rate must be readjusted each time the injection pressure is changed by more than 5psig. Most GCs have a low-flow needle valve that makes septum purge adjustments easy.

**Figure 9.**  
*Injector temperature affects the recovery of higher molecular weight compounds.*

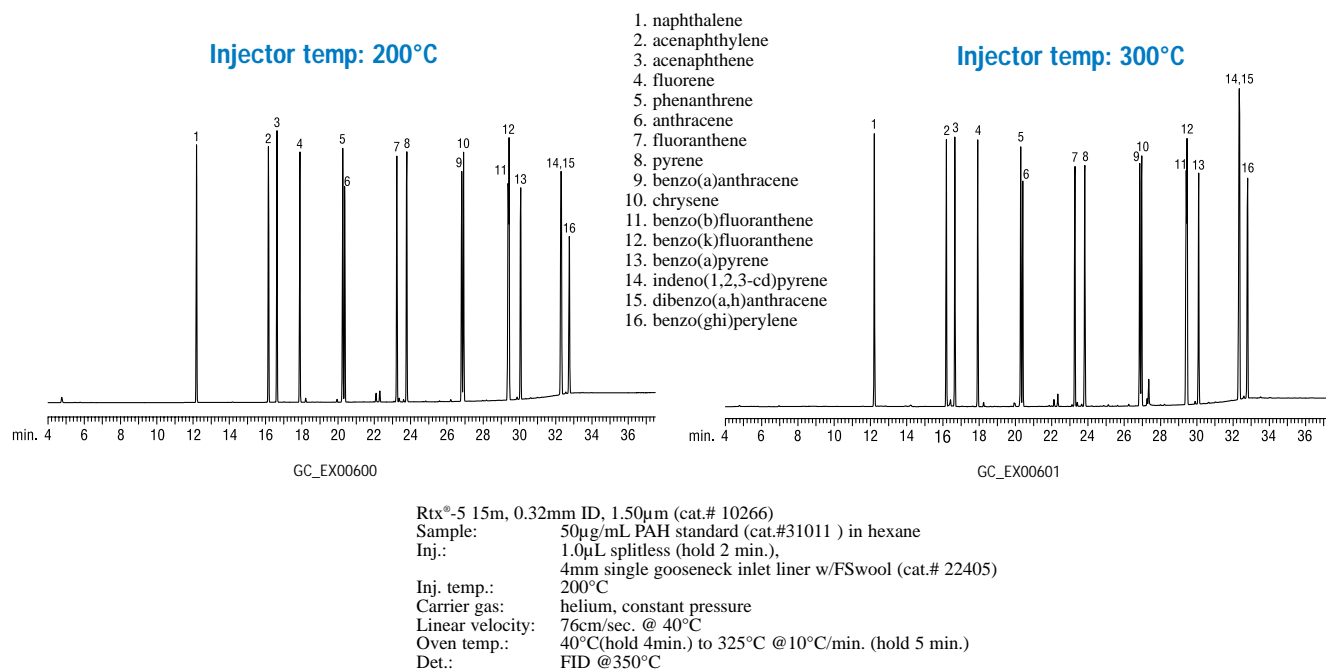

**Figure 10.**

*The Donike Test illustrates the importance of injector temperature when a sample contains thermally labile compounds.*

1. TMS tetracosanoate (thermolabile)
2. *n*-triacontane (stable)
3. TMS hexacosanoate (thermolabile)

15m x 0.32mm ID fused silica coated with 0.25 $\mu$ m bonded methyl silicone  
 Sample: 1 $\mu$ L each of TMS *n*-tetracosanoate, TMS *n*-hexacosanoate, and *n*-triacontane in *n*-nonane at 2ng/ $\mu$ L each component.

GC: 3000 Series Varian gas chromatograph with 1077 split/splitless injector, FID and autosampler.

Split/splitless injector:

Run 1: SPI held at 280 $^{\circ}$ C

Run 2: SPI held at 200 $^{\circ}$ C

Carrier gas: helium at 47cm/sec.

Oven: 130 $^{\circ}$  to 280 $^{\circ}$ C 20 $^{\circ}$ C/min. (hold 2 min.)

FID: 300 $^{\circ}$ C, 32 x 10 $^{-12}$

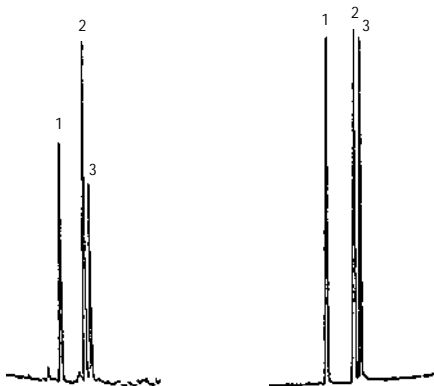

280 $^{\circ}$ C: Injector too hot, thermal degradation evident

200 $^{\circ}$ C: Injector temperature appropriate, breakdown minimized

Chromatograms courtesy of Varian Instrument Co.

## Problems Associated with Split and Splitless Injections

When performed properly, split and splitless injections are easy to automate, produce narrow peaks, and yield consistent run-to-run peak areas. However, split and splitless injections have inherent limitations associated with vaporizing the sample in a hot injection port.

**Thermal Decomposition:** The injection port temperature is a critical factor in optimizing hot vaporization injection techniques. If the injection port temperature is too low, high molecular weight analytes will not vaporize completely and will not be transferred to the head of the column efficiently (as shown by peaks 14, 15 and 16 in Figure 9). If the injection port temperature is too high, thermally labile compounds can break down inside the injection port before reaching the column. Figure 10 shows the effect of temperature on thermally labile TMS derivatives of fatty acids. When the injection port temperature is set at 280 $^{\circ}$ C, the response for the TMS derivatives is reduced. When the injection port temperature is lowered to 200 $^{\circ}$ C, the response for the TMS derivatives is comparable to triacontane at equivalent sample concentrations. Careful optimization of injection port temperatures will maximize sample vaporization while minimizing sample decomposition.

**Active Compounds:** Active compounds can be problematic in split or splitless injections. The high surface area and heat needed to uniformly vaporize the sample can cause these compounds to break down or be adsorbed onto the surface of the injection port liner. Deactivated inlet liners, and Silcosteel $^{\circ}$ -treated or gold-plated inlet seals can help minimize active sites in the injection port. If tailing peaks and poor response for active compounds cannot be corrected by using properly deactivated inlet liners and treated inlet seals, other injection techniques such as cold on-column or temperature-programmed injections should be considered.

**Molecular Weight Discrimination:** In hot vaporization injections, one injection port temperature is used to vaporize all of the analytes in one sample injection. Compounds spanning a range of molecular weights and boiling points will exhibit differences in response for equal concentrations of analyte. High molecular weight, high boiling point analytes will have a noticeably reduced response when compared to lower molecular weight, lower boiling point analytes. This effect is more pronounced when analyzing samples that have a broad range of molecular weights and boiling points. Samples containing analytes that are more closely grouped by molecular weight and boiling point show less molecular weight discrimination.

For customer service, call  
**800-356-1688, ext. 3**  
 (814-353-1300, ext. 3)  
 or call your local  
 Restek representative.

Figure 11.

*Splitter discrimination typical of split and splitless injections.*

Splitter discrimination is evident from relatively enhanced peak heights for the early-eluting compounds and diminished peak heights for the later-eluting higher molecular weight compounds. The same sample analyzed by cold on-column injection shows no discrimination; the peak heights for low and high molecular weight compounds are truly representative of this sample.

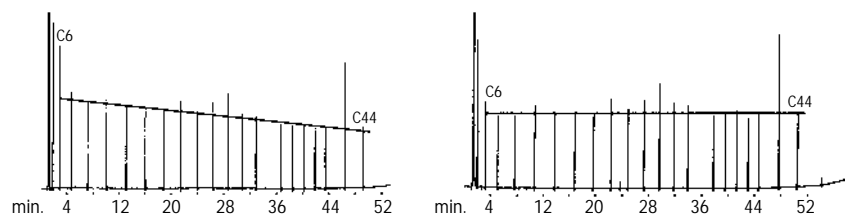

**Discrimination typical of a split or splitless injector. Injector temperature: 340°C**

30m, 0.32mm ID, 0.25 $\mu$ m Rtx<sup>®</sup>-1 (cat.# 10124)  
 Inj. volume: 0.2 $\mu$ L  
 On-column conc.: 15ng.  
 Oven temp.: 40°C to 340°C @ 5°C/min.

**Cold on-column injection provides accurate information. Injector temperature: 40°C.**

Det. (FID) temp.: 340°C  
 Linear velocity: 50cm/sec., hydrogen  
 Attenuation: 8x10<sup>-11</sup>AFS

Figure 11 demonstrates the molecular weight discrimination experienced when analyzing a series of hydrocarbons with a broad range of molecular weights (C6 through C44). Alternative injection techniques, such as cold on-column injection, can be used to minimize molecular weight discrimination.

Molecular weight discrimination is usually very repeatable. In split and splitless injections, if the same injection port temperature, carrier gas pressure, sample size and sample solvent are used for every injection, sample vaporization should be a reproducible process. Any molecular weight discrimination experienced should be the same from one injection to the next. Because of this consistency, many analysts choose to ignore molecular weight discrimination unless it compromises overall sensitivity. To help compensate for differences in response due to molecular weight discrimination, multiple internal standards can be used to mimic the range of molecular weights and boiling points for the analytes in the sample.

Molecular weight discrimination can be minimized by choosing an injection port liner that ensures the sample is completely and uniformly vaporized. Inadequate vaporization causes the sample to approach the head of the column in both the aerosol and vapor states. Aerosol droplets, consisting predominantly of high molecular weight compounds, can be driven past the head of the column by the momentum of the carrier gas and will be preferentially swept out of the injection port and through the split vent. Injection port liners that are packed with glass wool or that incorporate a flow diverting device within their bore assist in vaporizing the sample and transferring a homogeneous representation to the head of the column.

**Needle Discrimination:** During sample injections, the syringe needle undergoes some degree of heating in the injection port. The temperature reached by the needle can influence the relative response for low and high molecular weight analytes. During the process of expelling the sample from the syringe, the contents in the needle are not completely transferred to the injection port. As the needle begins to heat, low molecular weight analytes begin to vaporize from the needle while higher molecular weight analytes remain inside the needle. Therefore, the lower molecular weight analytes will show enhanced response compared to higher weight analytes (Figure 12). Three techniques can be used to minimize needle discrimination in split and splitless injections.

The first technique is to inject the sample as rapidly as possible. Rapid injections minimize the amount of time the needle spends in the injection port and reduces the amount of heating the needle experiences. When making rapid injections in straight injection port liners for split or splitless analysis, the sample can be propelled beyond the inlet of the column and onto the injector base fitting. Always pack injection port liners with deactivated glass wool or CarboFrit<sup>™</sup> packing, or use a flow diverting device like a laminar cup to assist in sample

Figure 12.

*Factors in discrimination: high molecular weight material clinging to the syringe needle and non-homogeneous vaporization of the sample in the inlet liner.*

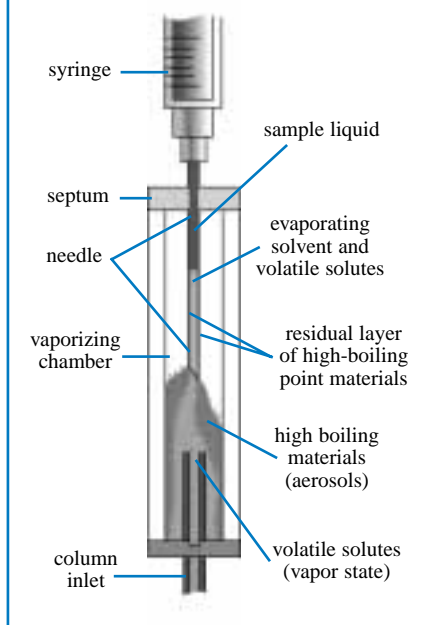
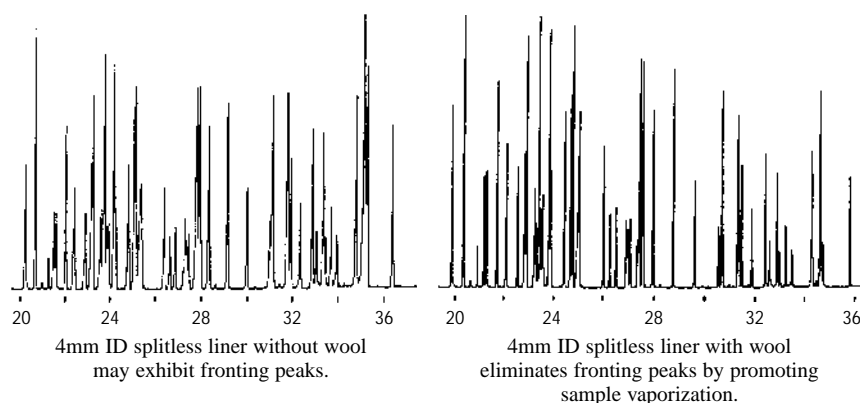

Figure 13.

Always pack splitless inlet liners with wool when using rapid injection autosamplers.



vaporization. Figure 13 shows the improvement in peak shape when an HP autosampler is used with an injection port liner packed with wool, versus a liner without wool.

The second technique is to use hot needle injection. Hot needle injections are performed by drawing the sample all the way into the syringe barrel, leaving the needle empty. When the needle is introduced into the injection port the injection is delayed for a short period of time (3–5 seconds, for example) to allow the needle to heat completely. Then the syringe plunger is depressed and the sample is expelled into the injection port liner.

The third technique is to use a solvent flush with each injection. This technique involves drawing a small amount of solvent into the syringe, followed by a small amount of air, followed by the desired amount of sample. All of the solvent, air, and sample are then drawn into the barrel of the syringe, just as in a hot needle injection. The needle is preheated, as in the hot needle injection, and the contents of the syringe are expelled into the injection port liner. The solvent that was first drawn into the syringe acts to flush the syringe barrel and needle, and completely transfers all of the sample during the injection process.

**Backflash:** Backflash occurs when the volume of the vaporized sample exceeds the volume inside the injection port liner. Most of the excess vaporized sample escapes out the top of the injection port liner. Some of it is swept down the septum purge line. Another portion of it can back up into the carrier gas supply line, and some of it can be re-introduced into the injection port. Backflash can cause poor peak area reproducibility, tailing peaks, split peaks, and poor resolution.

Table III (page 8) shows the estimated expansion volumes for 1 $\mu$ L injections of a variety of solvents. When using an injection port temperature of 250°C and a carrier gas pressure of 10psig, most solvents will vaporize and expand to a volume that exceeds the capacity of a 2mm ID injection port liner (approximately 240 $\mu$ L, see Table IV). In order to minimize backflash, injection port parameters must be carefully optimized. Injection port temperature, carrier gas pressure, sample size, and rate of injection all should be adjusted to ensure the vaporized sample remains inside the liner prior to being transferred to the head of the column.

**Sample Size and Injection Port Temperature:** As the equation in Table III shows, the volume of vaporized sample produced is directly related to the size of the liquid sample ( $n$ ) and the temperature of the injection port ( $T$ ). A decrease in either of these values will translate into a smaller vaporized sample volume. If the injection port temperature cannot be decreased because of vaporization problems and the sample size cannot be decreased because of sensitivity issues, backflash must be minimized by optimizing the rate of injection or by adjusting the carrier gas pressure.

Table IV.  
Liner Volumes.

	Theoretical*	Effective
1.0mm ID =	59 $\mu$ L	30 $\mu$ L
2.0mm ID =	236 $\mu$ L	118 $\mu$ L
3.0mm ID =	530 $\mu$ L	265 $\mu$ L
4.0mm ID =	942 $\mu$ L	471 $\mu$ L

\*Liner volume actually available for vaporization with carrier gas present is  $\leq 1/2$  theoretical, due to the presence of carrier gas in the liner.

From *Split and Splitless Injection in Capillary GC*, 3rd Ed., K. Grob, Wiley-VCH, 2001.

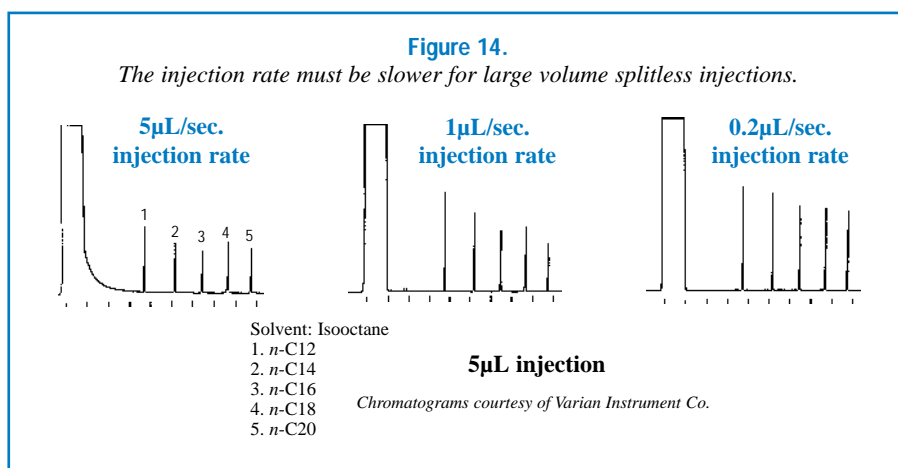

**Optimizing the Rate of Injection:** Figure 14 shows the effect of varying rates of injection for a 5µL sample. When a rapid injection (5µL/sec.) is made, the solvent peak tails and the responses for equal concentrations of each analyte are not reproducible. A 1µL/sec. injection rate improves the solvent peak shape, but the response for each analyte still is not proportional to the concentration of each analyte. Only when the injection rate is slowed to 0.2µL/sec. does the response for each analyte become consistent with the amount injected.

Some autosamplers are capable of slowing the injection rate to minimize backflash, but most autosamplers use a rapid injection sequence. If large-volume injections must be made rapidly, adjustments to the carrier gas pressure must be used to control sample expansion.

**Pressure Programming:** Pressure (P) is in the denominator of the equation in Table III (page 8). Any increase in carrier gas pressure will help to reduce sample expansion volume. Most of the latest models of GCs incorporate electronic pressure control (EPC) of the carrier gas pressure. Pressure can be time-programmed so that the carrier gas pressure initially is very high, then is reduced after the injection to optimize carrier gas flow rate for best resolution. Setting the initial carrier gas pressure to a high value will reduce the amount of sample expansion that occurs at the point of injection and will speed up the transfer of the vaporized sample from the liner to the head of the column.

## Direct Injection as an Alternative to Splitless Injection

Direct injections are an alternative approach for injecting samples with low concentrations of analytes. Direct injections vaporize the entire sample in a heated injection port, just like split and splitless injections. However, in direct injections, there is only one flow path through the injection port. All of the carrier gas is directed into the column and, hence, the entire vaporized sample is directed into the column as well. This can be accomplished by using a specially designed injection port liner. Unliner® injection port liners have an internal taper in one end that allows a direct connection between the liner and the capillary column. With this connection, the flow path from the injection port body through the split vent is blocked and all of the carrier gas flow is directed into the capillary column. Figure 15 illustrates how a Unliner® injection port liner with a Press-Tight® seal forms a leak-free connection between the liner and the column.

For customer service, call  
**800-356-1688, ext. 3**  
(814-353-1300, ext. 3)  
or call your local  
Restek representative.

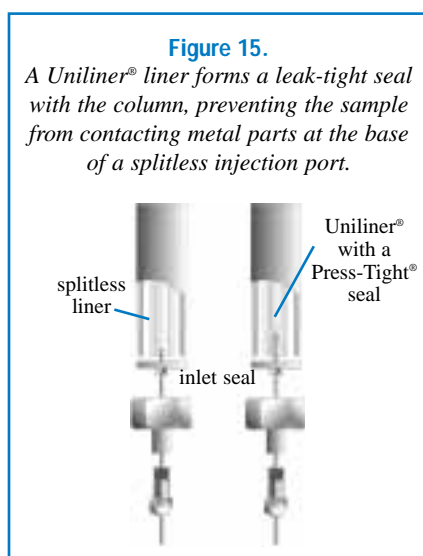

Because all of the carrier gas flow and the entire vaporized sample is directed into the capillary column, direct injections give comparable performance to splitless injections. Faster carrier gas flow rates usually are used to speed up the sample transfer process, and improve peak shapes and resolution. Direct injections can be used as another option to minimize molecular weight discrimination and loss of active compounds.

A Uniliner® inlet liner can be used as a direct replacement for a splitless liner. It can be installed in the same manner as a splitless liner, except that the system must be operated continuously with the solenoid valve closed. Uniliner® inlet liners are designed to accommodate 0.32 or 0.53mm ID columns. Request Restek's *Guide to Direct On-Column Vaporization Injection* (lit. cat.# 59882) for more information on how to perform and optimize direct injections.

#### *Standard Gooseneck Uniliner® Inlet Liner*



The buffer volume chamber contains the sample vaporization cloud and prevents analyte contact with metal injector parts. Peak tailing is reduced and larger injections can be made.

#### *Cyclo-Uniliner® Inlet Liner*



The glass cyclo spiral provides an excellent vaporization surface for high and low molecular weight samples. Particles are trapped on the first turn of the spiral, reducing subsequent residue/sample interaction. In comparison to liners packed with wool, Cyclo-Uniliner® liners accept up to five times as many injections of dirty samples before calibration curves degrade. Because they are deactivated, they are ideal for active samples.

#### *Open-top Uniliner® Inlet Liner*



Open-top Uniliner® liners are ideal for extremely dirty samples because they can be packed with fused silica wool to trap dirt and sample residue. Contaminated wool is easily replaced and the liner can be cleaned with a nylon brush or pipe cleaner.

#### *Drilled Uniliner® Inlet Liner*



A specially modified injection port liner, developed by Restek chemists, reduces sample contact with active metal parts in split/splitless injection ports. The Drilled Uniliner® liner gives the benefits of both direct injection and splitless injection. The column is connected to the liner by a press-fit connection, thus preventing the sample from contacting the metal at the bottom of the injection port. The hole on the side of the liner allows the purge flow to escape from the liner when the injection mode is switched from splitless to split.

## Deactivation

### *Siltek™ Deactivation*

- Revolutionary deactivation lowers endrin breakdown to less than 1%.
- Inertness retained over a wide range of sample pH.
- Minimal bleed.
- Recommended for difficult matrix and reactive compound analysis.
- Ideal for chlorinated pesticide analysis.
- Recommended for use with Rtx®-CL Pesticides, Stx-CL Pesticides, Stx-1HT, and Rtx®-TNT columns.

### *Base-Deactivation*

- Provides excellent inertness for basic compounds.
- Recommended for use with Rtx®-5 Amine, Rtx®-35 Amine, and Stabilwax®-DB columns.

### *Intermediate Polarity (IP) Deactivation*

Our standard deactivation for liners. Phenylmethyl-deactivated surface provides optimum compatibility for both polar and non-polar compounds.

In most cases, the standard IP deactivation should be chosen. The IP surface contains methyl groups, as well as phenyl groups, making this surface compatible with most common solvents.

For customer service, call  
**800-356-1688, ext. 3**

(814-353-1300, ext. 3)

or call your local  
Restek representative.

## Guard Columns

**Guard columns protect analytical columns in several ways:**

Guard columns trap non-volatile residues, preventing them from collecting at the analytical column inlet. These residues may be very high molecular weight organic compounds, inorganic salts, or particles. If these contaminants enter the analytical column, they can cause adsorption of active compounds, loss of resolution, and poor peak symmetry. When this contamination begins to affect sample analysis, a small section of the analytical column must be removed to restore proper performance. Each time a column section is removed, retention times change, and some resolution is lost. By using a guard column and removing contaminated loops from it instead of from the analytical column, analytical column length and inertness remain intact.

Guard columns also allow more injections to be made before contamination interferes with analytical results.

Because there is no stationary phase coated on a guard column, the amount of time the sample spends in the guard column is minimal. This reduces the interaction between sample components and contamination from non-volatile residue in the guard column.

For more information on selecting a guard column for your analysis, request our *Fast Facts* GC Capillary Column Guard Columns (lit. cat.# 59319).

## Mini Wool Puller/Inserter

Makes inserting and removing wool easy. Not recommended for double gooseneck liners.



Description	qty.	cat.#
Mini Wool Puller/Inserter	2-pk.	20114

## Hints for Analyzing Dirty Samples

When injecting dirty samples, non-volatile contaminants such as high molecular weight compounds, septum particles, derivatization reagents, salts, and pyrolyzed samples adhere to the interior wall of the injection port liner after the sample solvent and sample analytes have been vaporized. As this layer of residue thickens, it can cause loss of response for active compounds. Figure 16 illustrates this effect when highly active phenols are analyzed on a clean and a dirty inlet liner. In this example, responses are reduced because of adsorptive effects in the liner.

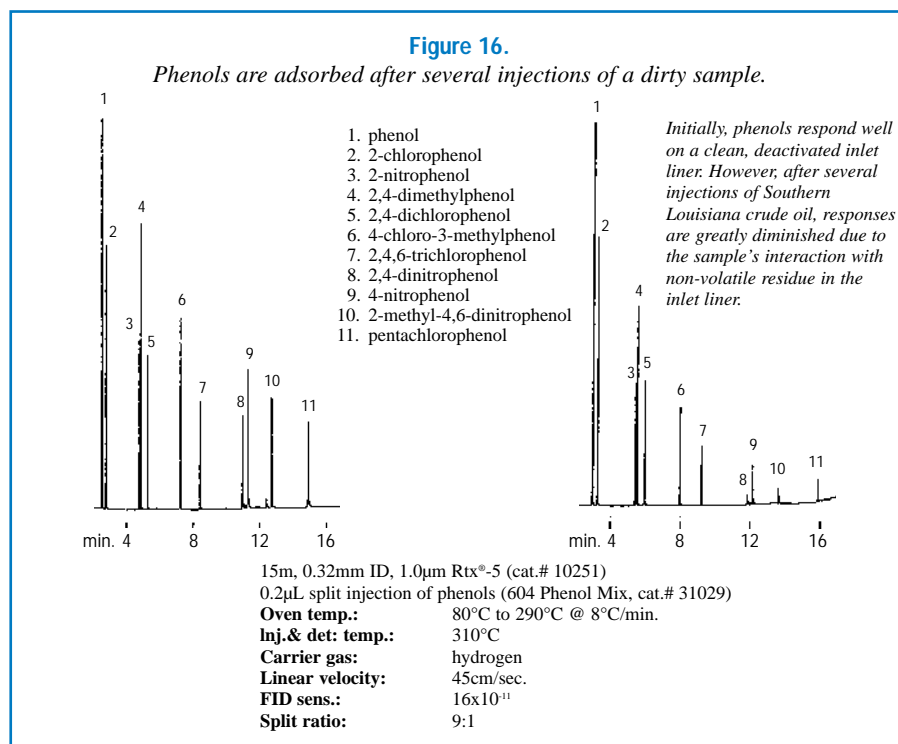

Non-volatile contamination can be trapped in the injection port liner by using a small plug of deactivated fused silica or glass wool. Usually a 1cm plug of wool, positioned in the center of the injection port liner, is sufficient to provide a surface for non-volatile contamination to collect. Some instrument manufacturers provide specific instructions on packing injection port liners to maximize quantitative accuracy and minimize discrimination. If fused silica wool or glass wool is used in an injection port liner, it should be replaced as part of the routine maintenance schedule for the injection port. Regular replacement of the wool in the injection port liner will extend the lifetime of the injection port liner as well as prevent chromatographic problems from extensive non-volatile contaminant build up. When replacing the wool during routine maintenance, minimize handling of the wool by using a wool puller tool (cat.# 20114).

If fused silica or glass wool is not an effective mode of trapping non-volatile contamination under your conditions, injection port liners with a “cyclo” or glass frit design can be used to trap non-volatile contamination. While these types of injection port liners may provide effective trapping of non-volatile contamination, they are harder to clean than straight injection port liners packed with wool.

In the past, some instruments were supplied with injection port liners that were packed with a small amount of packed column packing material. We do not recommend using this type of injection port liner. Diatomites used in packed column GC packings often are active and contain impurities that increase adsorptive effects for active compounds. Also, the stationary phases that are used in these packings can produce significant bleed when used in injection ports at elevated temperatures.

In addition to using a clean and deactivated injection port liner, we recommend using a five-meter deactivated guard column when analyzing dirty samples. Routine maintenance of the liner and the guard column will prevent dirty samples from contaminating the analytical column, and will help ensure reproducible and accurate analytical results.

## Hints for Performing Routine Injection Port Maintenance

Injection port maintenance should be performed prior to installing any capillary column. Maintenance of the injection port after a column is installed should be performed periodically, based on the number of injections made and the cleanliness of the samples. Maintenance includes cleaning, deactivating, or replacing injection port liners, and replacing critical inlet seals and the septum. Review the instrument manual inlet diagram prior to disassembling the inlet.

### Cleaning and Deactivating Injector Liners

For optimum column performance, the injection port liner must be free of septum particles, sample residue, and ferrule fragments. Use a deactivated injection port liner when analyzing samples with compounds that are active or prone to decomposition or adsorption on untreated glass surfaces. Table V illustrates the importance of a deactivated injection port liner when analyzing active compounds. The response factors (RF) for all three of these active compounds were much lower with non-deactivated inlet liners.

**Table V.**

*Deactivated inlet liners show higher response factors for active components.*

Compound	RF Deactivated Liner	RF Undeactivated Liner	RF relative to naphthalene; N=3
2,4-dinitrophenol	0.248	0.185	
pentachlorophenol	0.240	0.188	
benzidine	0.327	0.234	

If the injection port liner is deactivated and is not excessively dirty, cleaning with organic solvents usually is enough to restore original performance. Most organic solvents will not affect the integrity of the surface deactivation. First, remove septum particles that adhere to the inside wall of the injection port liner by rinsing with methanol or isopropanol. Next, use pentane, methylene chloride or toluene to remove sample residue. Do not use laboratory detergents, acids, or bases to clean injection port liners. Harsh cleaning agents will remove or damage the deactivation layer and the liner will require re-deactivation. Nylon brushes and pipe cleaners (cat.# 20108) can be used for mild abrasive cleaning of injection port liners.

### Replacing Critical Seals

Replace critical seals prior to installing an injection port liner (see the instrument manual for seal locations). In most capillary injection ports, an o-ring or ferrule made of rubber or graphite is used to seal the injection port liner into the injection port body. It is critical that the seal fits tightly around the liner, to prevent the carrier gas from leaking around the outside of the liner. Check for leaks with a thermal conductivity-type leak detector (e.g., Leak Detective™ II, cat.# 20413).

### Changing Septa

Always use a high-quality, low-bleed septum. We recommend replacing the septum frequently, to prevent leaks and fragmentation. Multiple injections and continuous exposure to hot injection port surfaces will decompose the septum and cause particles to fall into the injection port liner. Septum particles are a potential source of ghost peaks, loss of inertness, and carrier gas flow occlusion. It is best to install a new septum at the end of an analytical sequence so that it can condition in the injector and reduce the incidence of ghost peaks. To avoid contamination, always use forceps when handling septa. Restek's high quality, low-bleed Thermolite® septa are available for most common models of capillary GCs. For more information, request a copy of Restek's *Guide to Minimizing Septa Problems* (lit. cat.# 59886).

For additional hints for analyzing dirty samples, request a copy of Restek's *A Guide When Injecting Dirty Samples* (lit. cat.# 59881).

## Nylon Tube Brushes and Pipe Cleaner

Use to remove small septum fragments and residue from dirty glass inlet liners. Brushes are 1/8-, 3/16-, and 1/4-inch in diameter; pipe cleaner is one foot long.



Description	qty.	cat.#
Nylon Tube Brushes and Pipe Cleaner	set	20108

## Leak Detective™ II Leak Detector

- Affordable thermal conductivity leak detector—every analyst can have one.\*
- Compact, ergonomic design is easy to hold and operate with one hand.
- Helium, hydrogen, and nitrogen can be detected at  $1 \times 10^{-4}$  cc/sec. or at an absolute concentration as low as 100ppm.\*\*
- Fast results—responds in less than 2 seconds to trace leaks of gases with thermal conductivities different than air.
- Micro-chip design improves sensitivity and response time over previous models.
- Auto zeroing with the touch of a button.
- Battery-operated for increased portability (one 9-volt).



Description	qty.	cat.#
Leak Detective™ II Leak Detector (9 volt, Battery-Operated)	ea.	20413

\*Never use liquid leak detectors on a capillary system because liquids can be drawn into the column.

\*\*Caution: NOT designed for determining leaks of combustible gases. A combustible gas detector should be used for determining combustible gas leaks in possibly hazardous conditions.



## Siltek™ Deactivation—The Next Generation

- Maximizes the inertness of the sample pathway.
- Minimizes breakdown.
- Low bleed.
- Thermally stable.
- “Clean and green”—manufactured without the use of harmful organic solvents.

Restek offers the next generation of deactivation. The Siltek™ deactivation process (patent pending) produces a highly-inert glass surface, which features high temperature stability, extreme durability, and low bleed. Try Siltek™ liners, guard columns, wool, and connectors for better recovery of sample analytes.

**For Siltek™ inlet liners, add the corresponding suffix number to your liner catalog number.**

qty.	Siltek™	Siltek™ with Siltek™ wool	Siltek™ with CarboFrit™
each	-214.1 addl. cost	-213.1 addl. cost	-216.1 addl. cost
5-pk.	-214.5 addl. cost	-213.5 addl. cost	-216.5 addl. cost
25-pk.	-214.25 addl. cost	-213.25 addl. cost	-216.25 addl. cost

## Deactivation—Which Should You Choose?

### Siltek™ Deactivation

- Revolutionary deactivation lowers endrin breakdown to less than 1%.
- Inertness retained over a wide range of sample pH.
- Minimal bleed.
- Recommended for difficult matrix and reactive compound analysis.
- Ideal for chlorinated pesticide analysis.
- Recommended for use with Rtx®-CLPesticides, Stx-CLPesticides, Stx-IHT, and Rtx®-TNT columns.

### Base-Deactivation

- Provides excellent inertness for basic compounds.
- Recommended for use with Rtx®-5 Amine, Rtx®-35 Amine, and Stabilwax®-DB columns.

## Base-Deactivated Inlet Liners for Agilent GCs

If you do not see the deactivated liner you need, you can order it on a custom basis by adding the appropriate suffix number to the liner catalog number. For base deactivation: each (-210.1), 5-pack (-210.5), 25-pack (-210.25). For base-deactivated liners packed with base-deactivated wool: each (-211.1), 5-pack (-211.5), 25-pack (-211.25).

ea.	5-pk.	25-pk.
<b>4mm Split Straight w/ Wool</b>		
20781-211.1	20782-211.5	20783-211.25
<b>Cycloplitter®</b>		
20706-210.1	20707-210.5	-
<b>4mm Splitless Straight</b>		
20772-210.1	20773-210.5	20774-210.25
<b>2mm Gooseneck</b>		
20795-210.1	20796-210.5	20797-210.25
<b>4mm Gooseneck</b>		
20798-210.1	20799-210.5	20800-210.25

## Prepacked Liners

Let Restek do the work! Just add the appropriate suffix to the liner catalog number.

Prepacked Inlet Liners Suffix Numbers				
qty.	FS Wool	FS Beads	Glass Wool	CarboFrit™†
ea.	-200.1	-201.1	-202.1	-209.1
5-pk.	-200.5	-201.5	-202.5	-209.5
25-pk.	-200.25	-201.25	-202.25	-209.25

†CarboFrit™ inserts require a neck greater than 2mm.















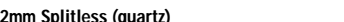

For customer service, call  
**800-356-1688, ext. 3**

(814-353-1300, ext. 3)

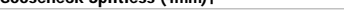
or call your local  
Restek representative.

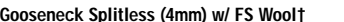
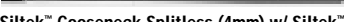
all liners are  
**100%**  
deactivated

## Liners for Agilent/Finnigan GCs

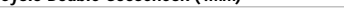
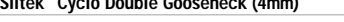
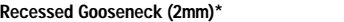
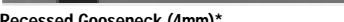
	Splitless Liners for Agilent/Finnigan GCs	Benefits/Uses:	ID**/OD & Length (mm)	Similar to Agilent part #	ea.	cat.# 5-pk.	25-pk.
C O L U M N M I N I S T A L L S T H I S E N D		trace samples <2µL	2.0 ID 6.5 OD x 78.5	18740-80220 5181-8818	20712	20713	20714
	<b>2mm Splitless</b>						
		trace samples >2µL	4.0 ID 6.5 OD x 78.5	19251-60540	20772	20773	20774
	<b>4mm Splitless</b>						
		trace samples >2µL	4.0 ID 6.5 OD x 78.5	19251-60540	20772-214.1	20773-214.5	20774-214.25
	<b>Siltek™ 4mm Splitless</b>	featuring <b>Siltek™</b> deactivation					
		trace samples >2µL	4.0 ID 6.5 OD x 78.5	19251-60540	22400	22401	22402
	<b>4mm Splitless w/ FS Wool</b>						
		trace samples <2µL	2.0 ID 6.5 OD x 78.5	18740-80220 5181-8818	20914	20915	-
	<b>2mm Splitless (quartz)</b>						
		trace samples >2µL	4.0 ID 6.5 OD x 78.5	18740-80220 5181-8818	20912	20913	-
	<b>4mm Splitless (quartz)</b>						
		trace samples >2µL	4.0 ID 6.5 OD x 78.5	18740-80220 5181-8818	22403	22404	-
	<b>4mm Splitless (quartz) w/ FS Wool</b>						
		trace samples <2µL	2.0 ID 6.5 OD x 78.5	5181-3316***	20795	20796	20797
	<b>Gooseneck Splitless (2mm)</b>						
		trace samples <2µL	2.0 ID 6.5 OD x 78.5	5181-3316***	20795-214.1	20796-214.5	20797-214.25
	<b>Siltek™ Gooseneck Splitless (2mm)</b>	featuring <b>Siltek™</b> deactivation					
		trace samples >2µL	4.0 ID 6.5 OD x 78.5	5181-3316	20798	20799	20800
	<b>Gooseneck Splitless (4mm)†</b>						
	trace samples >2µL	4.0 ID 6.5 OD x 78.5	5181-3316	20798-214.1	20799-214.5	20800-214.25	
<b>Siltek™ Gooseneck Splitless (4mm)†</b>	featuring <b>Siltek™</b> deactivation						
	trace samples >2µL	4.0 ID 6.5 OD x 78.5	5062-3587	22405	22406	22407	
<b>Gooseneck Splitless (4mm) w/ FS Wool†</b>							
	trace samples >2µL	4.0 ID 6.5 OD x 78.5	5062-3587	22405-213.1	22406-213.5	22407-213.25	
<b>Siltek™ Gooseneck Splitless (4mm) w/ Siltek™ Glass Wool†</b>	featuring <b>Siltek™</b> deactivation						
	trace, active samples >2µL	4.0 ID 6.5 OD x 78.5	5181-3315	20784	20785	20786	
<b>Double Gooseneck Splitless (4mm)</b>							
	trace, active samples >2µL	4.0 ID 6.5 OD x 78.5	5181-3315	20784-214.1	20785-214.5	20786-214.25	
<b>Siltek™ Double Gooseneck Splitless (4mm)</b>	featuring <b>Siltek™</b> deactivation						
	trace, active, dirty samples <2µL	2.0 ID 6.5 OD x 78.5	-	20907	20908	-	
<b>Cyclo Double Gooseneck (2mm)</b>							
	trace, active, dirty samples >2µL	4.0 ID 6.5 OD x 78.5	-	20895	20896	20997	
<b>Cyclo Double Gooseneck (4mm)</b>							
	trace, active, dirty samples >2µL	4.0 ID 6.5 OD x 78.5	-	20895-214.1	20896-214.5	20997-214.25	
<b>Siltek™ Cyclo Double Gooseneck (4mm)</b>	featuring <b>Siltek™</b> deactivation						
	base easily packs with wool for dirty samples <2µL	2.0 ID 6.5 OD x 78.5	-	20980	20981	20982	
<b>Recessed Gooseneck (2mm)*</b>							
	base easily packs with wool for dirty samples >2µL	4.0 ID 6.5 OD x 78.5	-	20983	20984	20985	
<b>Recessed Gooseneck (4mm)*</b>							
	base easily packs with wool for dirty samples >2µL	4.0 ID 6.5 OD x 78.5	-	20983-214.1	20984-214.5	20985-214.25	
<b>Siltek™ Recessed Gooseneck (4mm)*</b>	featuring <b>Siltek™</b> deactivation						
	base easily packs with wool for dirty samples > 2µL	4.0 ID 6.5 OD x 78.5	-	22408	22409	22410	
<b>Recessed Gooseneck (4mm)* w/ FS Wool</b>							
	base easily packs with wool for dirty, active samples > 2µL	4.0 ID 6.5 OD x 78.5	-	20986	20987	20988	
<b>Recessed Double Gooseneck (4mm)*</b>							

\*Use with two-hole ferrule for dual-column analysis.  
\*\*Nominal ID at syringe needle expulsion point.

\*\*\*Restek design changes improve performance over the original Agilent liner.

†Use this liner for increased sensitivity.

[www.restekcorp.com](http://www.restekcorp.com)



## O-Rings

### Viton® O-Rings

- For Agilent and PE AutoSys GCs.
- Viton® O-rings fit split (6.3mm OD) or splitless (6.5mm OD) liners.
- Graphite O-rings have excellent thermal stability.

Description	Max. temp.	Similar to Agilent part #	qty.	Restek cat.#
Viton® (fluorocarbon) O-rings	350°C	5180-4182	25-pk.	20377



### Graphite O-Rings

- For Agilent and Varian 1177 GCs.
- Excellent thermal stability at injection port temperature up to 450°C!

Description	Max. temp.	Similar to Agilent part #	Restek cat.#	
			10-pk.	50-pk.
6.35mm ID Graphite O-rings for split liners	450°C	5180-4168	20296	20297
6.5mm ID Graphite O-rings for splitless liners	450°C	5180-4173	20298	20299



### High-Temperature O-Rings

- Stable to 400°C.
- Will not crack or melt.
- Softer and easier to use than graphite.

Description	Max. temp.	qty.	cat.#
High-temperature O-rings	400°C	5-pk.	20437



## Inlet and FID Maintenance Kits for Agilent GCs

- Kits include the most common consumable supplies.
- All parts meet or exceed instrument manufacturer's specifications.
- Includes parts list that makes reordering easy.

### Inlet kits include:

- 0.4, 0.5, and 0.8mm ID graphite ferrules.
- Viton® o-rings.
- Capillary nuts.
- Inlet seals.
- Reducing nut.
- Scoring wafer.
- 11mm Thermolite® septa.
- 4.0mm single gooseneck liner.
- 4.0mm split liner with wool.
- Capillary column caps.
- 1/4- to 5/16-inch wrench.
- Septum puller.
- Installation gauge.
- Wire cleaning brush.
- Jet reamers/ferrule removers.
- Inlet liner removal tool.

### FID kits include:

- 1/4-Inch, 0.4, 0.5, and 0.8mm ID graphite
- FID/NPD capillary adaptor.
- Capillary nuts.
- Jet reamers/ferrule removers.
- 1/4-Inch nut.
- Scoring wafer.
- Capillary column caps.
- Ignitor for either Agilent 5890 or 6890/6
- FID flow measuring adaptor.
- 1/4- to 5/16-inch wrench.
- Installation gauge.
- Wire cleaning brush.
- High-performance Silcosteel®-treated FID jet for either Agilent 5890 or 6890/6850 GCs.
- 1/4-Inch nut driver for jet removal.



Description	qty.	cat.#
Inlet Maintenance Kit for Agilent 5890/6890/6850 GCs	kit	21069
FID Maintenance Kit for Agilent 5890 GCs	kit	21070
FID Maintenance Kit for Agilent 6890/6850 GCs	kit	21071

## Vespel® Ring Inlet Seals for Agilent 5890/6890 and 6850 GCs

- Easy-to-use, patent-pending design makes a better seal, easily.
- Prevents oxygen from damaging your columns.
- Reduces wear on the injection port body.

In Agilent split/splitless injection ports, it can be difficult to make and maintain a good seal with a conventional metal inlet disk. The metal-to-metal seal dictates that the analyst apply considerable torque to the reducing nut, and, based on our testing, this does not ensure a leak-tight seal. Over the course of oven temperature cycling, metal seals are prone to leaks, which ultimately can degrade the capillary column, and cause other analytical difficulties.

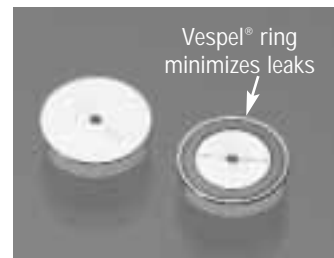

**Figure 1**

The Vespel® Ring Inlet Seal achieves leak-tight seals even at low torque, reducing the chance of leaks.

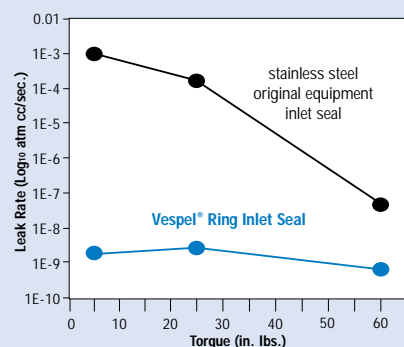

Our Vespel® Ring Inlet Seal greatly improves injection port performance—it seals even after repeated temperature cycles and without retightening the reducing nut! This seal features a Vespel® ring embedded into its face. This soft Vespel® ring will not harm the critical seal on the injector body, and is outside the sample flow path. Tests using a high sensitivity helium leak detector indicate the Vespel® Ring Inlet Seal seals equally effectively at torques of 5lb. or 60lb. (Figure 1).

Why trust a metal-to-metal seal when you can make leak-tight seals quickly and easily—and more reliably—with the Restek Vespel® Ring Inlet Seal? Use the stainless steel seal for analysis of unreactive compounds. To reduce breakdown and adsorption of active compounds, use the gold-plated or Silcosteel®-treated seals. The gold surface offers better inertness than standard stainless steel; Silcosteel® treatment provides inertness similar to that of fused silica capillary columns.

### Vespel® Ring Inlet Seals for Agilent 5890/6890/6850 GCs

0.8mm ID Vespel® Ring Inlet Seal (washers included)	2-pk.	10-pk.
Gold-Plated	21562	21563
Silcosteel®	21564	21565
Stainless Steel	21560	21561
1.2mm ID Vespel® Ring Inlet Seal (washers included)	2-pk.	10-pk.
Gold-Plated	21568	21569
Silcosteel®	21570	21571
Stainless Steel	21566	21567



**Achieve a better seal!**

### Re-Threading Tool

- Repair worn or damaged threads.
- Multiple uses (injection ports, fittings, etc.).
- Built-in guide to prevent cross-threading.

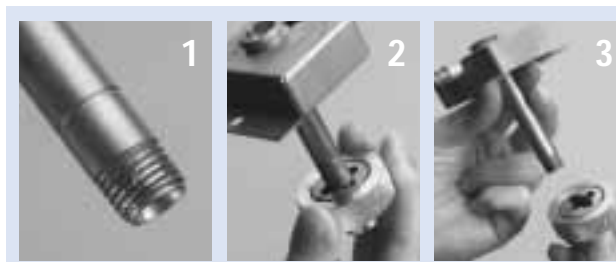

1) Worn & damaged threads can allow oxygen into the system—compromising analytical results and destroying columns.

2) Screw the tool completely onto the injection port in a clockwise direction.

3) Unscrew the tool and inspect the threads, repeat as necessary, and, when done, wipe threads with methanol to remove any debris.

Description	qty.	cat.#
Re-threading Tool for 1/8" compression fitting for Agilent split/splitless injection ports	ea.	23018

## Replacement Inlet Seals

- Special grade of stainless steel that is softer and deforms more easily, ensuring a completely leak-free seal.
- Increases column lifetime because oxygen cannot permeate into the carrier gas.
- Reduced noise benefits high-sensitivity detectors (e.g., ECDs, MSDs).
- Silcosteel® seal offers the inertness of glass.
- All seals include washers.

### Replacement Inlet Seals for Agilent 5890/6890/6850 Split/Splitless Injection Ports

The inlet seal at the base of the Agilent 5890/6890 GC injection port contacts the sample and must be changed frequently to prevent adsorption of active compounds. In addition, septum fragments and sample residue accumulate on the disk surface, requiring disk replacement.

The inlet seal design increases column lifetime because oxygen cannot permeate into the carrier gas. Detector noise also is reduced with high-sensitivity detectors (e.g., ECDs or MSDs). To reduce breakdown and adsorption of active compounds, use the gold-plated or Silcosteel® seals. The gold surface offers better inertness than standard stainless steel, and the Silcosteel® treatment offers inertness similar to that of fused silica capillary columns.

Single-Column Installation, Opening Size 0.8mm ID*		0.25/0.32mm ID Dual-Column Installation, Opening Size 1.2mm ID		0.53mm ID Dual-Column Installation Opening Size (1/16-inch hole)	
2-pk.	10-pk.	2-pk.	10-pk.	2-pk.	10-pk.
<b>Stainless Steel Inlet Seal</b>					
21315	21316	20390	20391	20392	20393
<b>Gold-Plated Inlet Seal</b>					
21317	21318	21305	21306	—	—
<b>Silcosteel® Inlet Seal</b>					
21319	21320	21307	21308	—	—

\*0.8mm ID stainless steel inlet seal is equivalent to Agilent part #18740-20880,  
0.8mm ID gold-plated inlet seal is equivalent to Agilent part #18740-20885.

## Replacement Inlet Cross-Disk Seal for Agilent GCs

- Ideal for high-flow split applications on Agilent 5890 GCs.
- All seals include washers.



















(Similar to Agilent part # 5182-9652.)

0.8mm ID Cross-Disk Inlet Seal for Agilent GCs	2-pk.	10-pk.
Gold-Plated	20477	20476
Silcosteel®	20475	20474
1.2mm ID Cross-Disk Inlet Seal for Agilent GCs	2-pk.	10-pk.
Gold-Plated	21009	21010
Silcosteel®	21011	21012

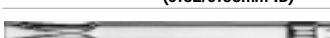

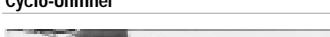
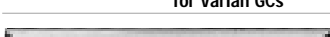
all liners are  
**100%**  
deactivated **Liners for Varian GCs**

C O L U M N S T A T I S T I C S E N D

Splitless Liners for Varian 1075/1077 GCs		Benefits/Uses:	ID**/OD & Length (mm)	Similar to Varian part #	ea.	cat.# 5-pk.	25-pk.
	2mm Splitless	trace samples <2µL	2.0 ID 6.3 OD x 74	01-900109-05	20721	20722	20723
	4mm Splitless	trace samples >2µL	4.0 ID 6.3 OD x 74	01-900109-05	20904	20905	20906
	Double Gooseneck	trace, active samples up to 4µL	4.0 ID 6.3 OD x 74	-	20847	20848	20849
	Cyclo Double Gooseneck	trace, dirty, active samples up to 4µL	4.0 ID 6.3 OD x 74	-	20897	20898	-
Split Liners for 1075/1077 Varian GCs		Benefits/Uses:	ID**/OD & Length (mm)	Similar to Varian part #	ea.	cat.# 5-pk.	25-pk.
	1mm Split	purge & trap inlet splitting or samples <1µL	1.0 ID 6.3 OD x 72	-	20970	20971	-
	Splitter with Wool*	universal, use with rapid autosamplers	4.0 ID 6.3 OD x 72	01-900109-01	20792	20793	20794
	Laminar Cup Splitter	high MW compounds	4.0 ID 6.3 OD x 72	01-900109-02	20803	20804	-
	Cup Splitter	high & low MW compounds	4.0 ID 6.3 OD x 72	-	20724	20725	-
	Cycloplitter*	dirty samples, many injections before cleaning required	4.0 ID 6.3 OD x 72	-	20727	20728	-
	Frit Splitter	dirty samples, non-active compounds	4.0 ID 6.3 OD x 72	01-900109-03	20715	20716	20717
	Baffle Splitter	close boiling compounds	4.0 ID 6.3 OD x 72	01-900109-04	20718	20719	20720
	Split Precision™ Liner	dirty samples, active samples	4.0 ID 6.3 OD x 72	-	21030	21031	-
DI Liners for Varian 1075/1077 GCs (0.32/0.53mm ID)		Benefits/Uses:	ID**/OD & Length (mm)	Similar to Varian part #	ea.	cat.# 5-pk.	25-pk.
	Uniliner®	trace, active samples, high recovery & linearity	4.0 ID 6.3 OD x 72	-	20345	20346	-
	Cyclo-Uniliner®	trace, dirty, high MW, active samples, linearity	4.0 ID 6.3 OD x 72	-	20347	20348	-
	Open-top Uniliner® with Wool*	trace, dirty, active samples, high recovery & linearity	4.0 ID 6.3 OD x 72	-	20845	20846	-
SPI Liners for Varian GCs		Benefits/Uses:	ID**/OD & Length (mm)	Similar to Varian part #	ea.	cat.# 5-pk.	25-pk.
	0.5mm SPI	high linearity for 0.25 & 0.32mm ID columns	0.53 ID 4.6 OD x 54	01-900109-06	20775	20776	20777
	Siltek™ 0.5mm SPI	high linearity for 0.25 & 0.32mm ID columns	0.53 ID 4.6 OD x 54	01-900109-06	20775-214.1	20776-214.5	20777-214.25
	0.8mm SPI	high linearity for 0.53mm ID columns	0.80 ID 4.6 OD x 54	01-900109-07	20778	20779	20780
	SPI with Buffer	dirty samples >1µL, fits 0.25, 0.32 & 0.53mm ID columns	2.4 ID 4.6 OD x 54	01-900109-08	20850	20851	20852











featuring  
**Siltek™**  
deactivation

\*Packed with fused silica wool. For glass wool instead, add the suffix "-202" to the liner catalog number.  
\*\*Nominal ID at syringe needle expulsion point.

all liners are  
**100%**  
deactivated

## Liners for Varian GCs

C  
O  
L  
U  
M  
N  
I  
N  
S  
T  
A  
L  
L  
S  
T  
H  
I  
S  
E  
N  
D

Liners for Varian 1177 GCs		Benefits/Uses:	ID**/OD & Length (mm)	Similar to Varian part #	ea.	cat.# 5-pk.	25-pk.
	4mm Split	universal	4.0 ID 6.3 OD x 78.5	39-26119-36	21045	21046	-
	2mm Splitless w/wool*	trace samples <2µL	2.0 ID 6.5 OD x 78.5	39-26119-38	-	21077	-
	4mm Split w/wool*	universal	4.0 ID 6.3 OD x 78.5	39-26119-37	-	21079	-
1078/1079 Liners for Varian GCs		Benefits/Uses:	ID**/OD & Length (mm)	Similar to Varian part #	ea.	cat.# 5-pk.	25-pk.
	1078/1079 Split	dirty samples, non-active compounds	3.4 ID 5.0 OD x 54	03-918464-00	21708	21709	-
	1078/1079 Splitless	trace samples <2µL	2.0 ID 5.0 OD x 54	03-918466-00	21711	21712	-
	Siltek™ 1078/1079 Splitless	trace samples <2µL	2.0 ID 5.0 OD x 54	03-918466-00	21711-214.1	21712-214.5	-
	Open 0.5mm ID	trace samples <1µL	0.5 ID 5.0 OD x 54	03-925331-00	20992	20993	-
	1078/1079 Split-No Frit	active samples	3.4 ID 5.0 OD x 54	03-918464-00	20859	20901	20909
	Siltek™ 1078/1079 Split-No Frit	active samples	3.4 ID 5.0 OD x 54	03-918464-00	20859-214.1	20901-214.5	20909-214.25
	Open 0.75mm ID	trace, low volume samples	0.75 ID 5.0 OD x 54	03-925330-00	21714	21715	21716
	1078/1079 Split Precision™ Liner	trace samples, dirty samples	3.4 ID 5.0 OD x 54	-	21024	21025	-

\*Packed with fused silica wool. For glass wool instead, add the suffix "-202" to the liner catalog number.

\*\*Nominal ID at syringe needle expulsion point.

## Inlet Liner Seals for Varian 1177 Injectors

Meets original equipment specifications.

(Similar to Varian part # 39-26119-40.)

Description	qty.	cat.#
Inlet Liner Seals for Varian 1177 Injectors	10-pk.	20298

## 5mm Liner Seals for Varian 1078/1079 GCs

Description	qty.	cat.#
5mm Liner Seals for Varian 1078/1079 GCs	10-pk.	22683

## Inlet Liner Removal Tool

- Easily remove liners from injectors.
- Made from high-temperature silicone.
- Won't chip or crack the liner.

Description	qty.	cat.#
Inlet Liner Removal Tool	3-pk.	20181

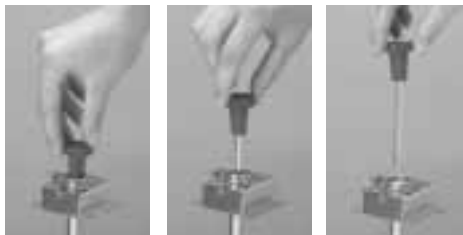













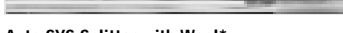





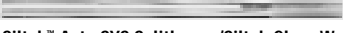

*No more burned fingers!*

all liners are  
**100%**  
deactivated

## Liners for PerkinElmer GCs

C O L U M N S T A L L S A T A R T I N G M U L T I P L E

Split Liners for PerkinElmer GCs	Benefits/Uses:	ID**/OD & Length (mm)	Similar to PE part #	ea.	cat.# 5-pk.	25-pk.
 <b>Baffle Splitter</b>	universal, for most common analyses	3.5 ID 5.0 OD x 100	0330-5181	20736	20737	-
 <b>Cup Splitter</b>	high & low MW compounds	3.5 ID 5.0 OD x 100	-	20739	20740	-
 <b>Cyclo-splitter®</b>	dirty samples, max. injections before cleaning required	3.5 ID 5.0 OD x 100	-	20745	20746	-
 <b>Laminar Cup Splitter</b>	high MW compounds	3.5 ID 5.0 OD x 100	-	20805	20806	-
 <b>Auto SYS Splitter with Wool*</b>	universal for most common analyses	4.0 ID 6.2 OD x 92.1	N6101052	20832	20833	20834
 <b>Siltek™ Auto SYS Splitter w/ Siltek™ Glass Wool deactivation</b>	universal for most common analyses	4.0 ID 6.2 OD x 92.1	N6101052	20832-213.1	20833-213.5	20834-213.25
 <b>Auto SYS Cup Splitter</b>	high & low MW compounds	4.0 ID 6.2 OD x 92.1	-	20835	20836	-
 <b>Auto SYS Cyclo-splitter®</b>	dirty samples, max. injections before cleaning required	4.0 ID 6.2 OD x 92.1	-	20910	20911	-
 <b>Auto SYS Laminar Cup Splitter</b>	high MW compounds	4.0 ID 6.2 OD x 92.1	-	20827	20828	-
 <b>Auto SYS Split Precision™ Liner</b>	dirty samples, trace samples	4.0 ID 6.2 OD x 92.1	-	21026	21027	-
<b>Splitless Liners for PerkinElmer GCs</b>	<b>Benefits/Uses:</b>	<b>ID**/OD &amp; Length (mm)</b>	<b>Similar to PE part #</b>	<b>ea.</b>	<b>cat.# 5-pk.</b>	<b>25-pk.</b>
 <b>Splitless (2mm ID)</b>	trace samples	2.0 ID 5.0 OD x 100	0330-5180	20730	20731	20732
 <b>Auto SYS Splitless w/Wool (2mm ID)*</b>	trace samples	2.0 ID 6.2 OD x 92.1	N6101372	20829	20830	20831
 <b>Siltek™ Auto SYS Splitless w/Siltek Glass Wool (2mm ID)</b>	trace samples	2.0 ID 6.2 OD x 92.1	N6101372	20829-213.1	20830-213.5	20831-213.25
 <b>Auto SYS Double Gooseneck</b>	trace, active samples up to 4µL	4.0 ID 6.2 OD x 92.1	-	20853	20854	-
 <b>Auto SYS Cyclo Double Gooseneck</b>	trace, dirty, active samples, up to 4µL	4.0 ID 6.2 OD x 92.1	-	20899	20900	-
<b>DI Liners for PerkinElmer GCs (0.32/0.53mm ID)</b>	<b>Benefits/Uses:</b>	<b>ID**/OD &amp; Length (mm)</b>	<b>Similar to PE part#</b>	<b>ea.</b>	<b>cat.# 5-pk.</b>	<b>25-pk.</b>
 <b>Uniliner®</b>	trace, active samples, high recovery & linearity	3.5 ID 5.0 OD x 100	-	20855	20856	-
 <b>Cyclo-Uniliner®</b>	trace, dirty, active samples, high linearity	3.5 ID 5.0 OD x 100	-	20857	20858	-
 <b>Auto SYS Open-top Uniliner® w/Wool*</b>	trace, dirty, active samples, high recovery & linearity	4.0 ID 6.2 OD x 92.1	-	20837	20838	-
 <b>Auto SYS Cyclo-Uniliner®</b>	trace, dirty, high MW active samples, high linearity	4.0 ID 6.2 OD x 92.1	-	20839	20840	-
 <b>Auto SYS Drilled Uniliner®</b>	allows direct injection when using an EPC-equipped GC	4.0 ID 6.2 OD x 92.1	-	20819	20822	-



















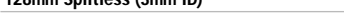

\*Prepacked with fused silica wool. For glass wool instead, add the suffix "-202" to the liner catalog number.

\*\*Nominal ID at syringe needle expulsion point.

all liners are  
**100%**  
deactivated

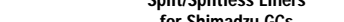
## Liners for Shimadzu GCs

C  
O  
L  
U  
M  
N  
S  
I  
N  
S  
T  
A  
L  
L  
S  
T  
H  
I  
S  
E  
N  
D

Split Liners for Shimadzu GCs	Benefits/Uses:	ID**/OD & Length (mm)	Similar to Shimadzu part #	ea.	cat.# 5-pk.	25-pk.
 <b>17A 1mm Split</b>	purge & trap & fast GC	1.0 ID 5.0 OD x 95	-	20976	20977	20978
 <b>128mm Split</b>	universal, for most common analyses	3.5 ID 5.0 OD x 128	221-25822-01	20751	20752	20753
 <b>128mm Cycloplitter®</b>	dirty samples, many injections before cleaning required	3.5 ID 5.0 OD x 128	-	20754	20755	-
 <b>128mm Cup Splitter</b>	high & low MW compounds	3.5 ID 5.0 OD x 128	-	20757	20758	-
 <b>128mm Laminar Cup Splitter</b>	high MW compounds	3.5 ID 5.0 OD x 128	-	20807	20808	-
 <b>99mm Split</b>	universal, for most common analyses	3.5 ID 5.0 OD x 99	221-32544-01	20860	20861	20862
 <b>99mm Cycloplitter®</b>	dirty samples, many injections before cleaning required	3.5 ID 5.0 OD x 99	-	20870	20871	-
 <b>99mm Cup Splitter</b>	high MW compounds	3.5 ID 5.0 OD x 99	-	20866	20867	-
 <b>99mm Laminar Cup Splitter</b>	high MW compounds	3.5 ID 5.0 OD x 99	-	20868	20869	-
 <b>17A Split Precision™ Liner</b>	trace samples, dirty samples	3.5 ID 5.0 OD x 95	-	21020	21021	-
<b>Splitless Liners for Shimadzu GCs</b>	<b>Benefits/Uses:</b>	<b>ID**/OD &amp; Length (mm)</b>	<b>Similar to Shimadzu part #</b>	<b>ea.</b>	<b>cat.# 5-pk.</b>	<b>25-pk.</b>
 <b>128mm Splitless (3mm ID)</b>	trace samples	3.5 ID 5.0 OD x 128	221-25440-03	20748	20749	20750
 <b>99mm Splitless (3mm ID)</b>	trace samples	3.5 ID 5.0 OD x 99	221-32544-00	20863	20864	20865
 <b>17A 95mm Double Gooseneck</b>	reduces backflash and catalytic decomposition	3.5 ID 5.0 OD x 95	-	20958	20959	20960
 <b>17A 95mm Single Gooseneck</b>	reduces backflash, also operates in DI mode	3.5 ID 5.0 OD x 95	221-41599-00	20961	20962	20963
<b>Split/Splitless Liners for Shimadzu GCs</b>	<b>Benefits/Uses:</b>	<b>ID**/OD &amp; Length (mm)</b>	<b>Similar to Shimadzu part #</b>	<b>ea.</b>	<b>cat.# 5-pk.</b>	<b>25-pk.</b>
 <b>17A 95mm Split/Splitless with Wool*</b>	universal, for most common analyses	3.5 ID 5.0 OD x 95	221-41444-00	20955	20956	20957
 <b>Siltek™ 95mm Split/Splitless w/ Siltek™ Glass Wool</b>	universal, for most common analyses	3.5 ID 5.0 OD x 95	221-41444-00	20955-213.1	20956-213.5	20957-213.25
<b>DI Liners for Shimadzu GCs (0.32/0.53mm ID)</b>	<b>Benefits/Uses:</b>	<b>ID**/OD &amp; Length (mm)</b>	<b>Similar to Shimadzu part #</b>	<b>ea.</b>	<b>cat.# 5-pk.</b>	<b>25-pk.</b>
 <b>128mm Uniliner®</b>	trace, active samples, high recovery & linearity	3.5 ID 5.0 OD x 128	-	20872	20873	-
 <b>128mm Cyclo-Uniliner®</b>	trace, dirty, high MW active samples, high linearity	3.5 ID 5.0 OD x 128	-	20874	20875	-
 <b>99mm Uniliner®</b>	trace, active samples, high recovery & linearity	3.5 ID 5.0 OD x 99	-	20876	20877	-
 <b>99mm Cyclo-Uniliner®</b>	trace, dirty, high MW active samples, high recovery & linearity	3.5 ID 5.0 OD x 99	-	20893	20894	-
 <b>95mm Uniliner® with Wool*</b>	trace, dirty, high MW active samples, high recovery & linearity	3.5 ID 5.0 OD x 95	-	21713	21719	-

















\*This liner is prepacked with fused silica wool. To order glass wool instead, add the suffix "-202" to the liner catalog number.

\*\*Nominal ID at syringe needle expulsion point.

all liners are  
**100%**  
deactivated

## Liners for Thermo Finnigan

C  
O  
L  
U  
M  
N  
S  
T  
A  
B  
I  
L  
I  
T  
Y  
S  
E  
L  
E  
C  
T  
I  
O  
N  
S  
D

Split Liners for 5000-6000 Series GCs		Benefits/Uses:	ID**/OD & Length (mm)	Similar to TF part #	ea.	cat.# 5-pk.	25-pk.
	Laminar Cup Splitter	high MW compounds	4.0 ID 5.4 OD x 79.5	-	20809	20810	-
	Cycloplitter®	dirty samples, many injections before cleaning required	4.0 ID 5.4 OD x 79.5	-	20817	20818	-
	Cup Splitter Gooseneck	high & low MW compounds	4.0 ID 5.4 OD x 79.5	-	20885	20886	-
Splitless Liners for 5000-6000 Series GCs		Benefits/Uses:	ID**/OD & Length (mm)	Similar to TF part #	ea.	cat.# 5-pk.	25-pk.
	Splitless (2mm ID)	trace samples	2.0 ID 5.4 OD x 79.5	-	20811	20812	20813
	Splitless (4mm ID)	trace samples	4.0 ID 5.4 OD x 79.5	-	20814	20815	20816
DI Liners for 5000-6000 Series GCs (0.32/0.53 ID)		Benefits/Uses:	ID**/OD & Length (mm)	Similar to TF part #	ea.	cat.# 5-pk.	25-pk.
	Open-top Uniliner® w/Wool*	trace, dirty, active samples, high recovery & linearity	4.0 ID 5.4 OD x 79.5	-	20841	20842	-
Split Liners for 8000 & TRACE™ Series GCs		Benefits/Uses:	ID**/OD & Length (mm)	Similar to TF part #	ea.	cat.# 5-pk.	25-pk.
	1mm Split	purge & trap & fast GC	1.0 ID 8.0 OD x 105	453 20075	20916	20917	-
	3mm Split	universal	3.0 ID 8.0 OD x 105	453 20031	20936	20937	20938
	5mm Split	universal	5.0 ID 8.0 OD x 105	453 20030	20939	20940	20941
	Laminar Cup Splitter	high MW compounds	4.0 ID 8.0 OD x 105	-	20948	20949	-
	Cup Splitter	high & low MW compounds	4.0 ID 8.0 OD x 105	-	20950	20951	-
	5mm Split Precision™ Liner	trace samples, dirty samples	5.0 ID 8.0 OD x 105	-	21028	21029	-
Splitless Liners for 8000 & TRACE™ Series GCs		Benefits/Uses:	ID**/OD & Length (mm)	Similar to TF part #	ea.	cat.# 5-pk.	25-pk.
	Splitless (3mm ID)	trace samples	3.0 ID 8.0 OD x 105	453 20032	20942	20943	20944
	Siltek™ Splitless (3mm ID)	trace samples	3.0 ID 8.0 OD x 105	453 20032	20942-214.1	20943-214.5	20944-214.25
	Splitless (5mm ID)	trace samples	5.0 ID 8.0 OD x 105	453 20033	20945	20946	20947
	Double Gooseneck	trace active samples up to 4µL	4.0 ID 8.0 OD x 105	-	20952	20953	-



\*Prepacked with fused silica wool. For glass wool instead, add the suffix "-202" to the liner catalog number.

\*\*Nominal ID at syringe needle expulsion point.

all liners are  
100%  
deactivated

## Liners for Thermo Finnigan

COLUMN INSTALLS THIS END

DI Liners for 8000 & TRACE™ Series GCs		Benefits/Uses:	ID**/OD & Length (mm)	Similar to TF part #	ea.	cat.# 5-pk.	25-pk.
	Uniliner® w/Wool	trace, active samples, high recovery, & linearity	5.0 ID 8.0 OD x 105	-	21005	21006	-
Split Liners for TRACE™ 2000 GCs		Benefits/Uses:	ID**/OD & Length (mm)	Similar to TF part #	ea.	cat.# 5-pk.	25-pk.
	1mm ID Trace 2000 Glass Liner	trace samples, high recovery & linearity	1mm ID 2.95 OD x 120	-	21114	21115	-
	2mm ID Trace 2000 Glass Liner	universal	2mm ID 2.95 OD x 120	-	21116	21117	-

\*\*Nominal ID at syringe needle expulsion point.

### Inlet Liner Seal for TRACE™ 2000 GCs

Description	qty.	cat.#
Inlet Liner Seal	2-pk.	21392



### Graphite Sealing Ring and Washer for 8000 Series and TRACE™ GC Inlet Liners

(Similar to Thermo Finnigan part # 290-03406)

Description	qty.	cat.#
Graphite Sealing Ring and Washer	ea.	21898
Graphite Sealing Rings and Washers	2-pk.	21899



### Graphite Ferrules for M4 Fittings

- High-purity, high-density graphite.
- Smoother surface and cleaner edges than conventional graphite ferrules.
- Contain no binders that can off-gas or adsorb analytes.
- Stable to 450°C.



### Graphite Ferrules for M4 Fittings for QCQ Thermo Finnigan 8000 & TRACE™ 2000

Ferrule ID	Fits Column ID	Graphite 2-pk.	Graphite 10-pk.
0.4mm*	0.18–0.25mm	20280	20281
0.5mm*	0.28/0.32mm	20282	20283
0.8mm*	0.45/0.50 & 0.53mm	20284	20285

\*0.4mm ID ferrule is similar to Thermo Finnigan part #290-13488, 0.5mm ID ferrule is similar to Thermo Finnigan part #290-13487, and 0.8mm ID ferrule is similar to Thermo Finnigan part #290-13486.

## handy Septum Size Chart

Instrument	Septum Size
Agilent (HP)	
5880A, 5890, 6890, 6850	11mm
5700, 5880	9.5/10mm
On-Column Injection	
	5mm
CE Instruments (TMO)	
TRACE GC	17mm
Finnigan (TMO)	
GC 9001	9.5mm
GCQ	9.5mm
GCQ w/TRACE	17mm
QCQ™	9.5mm
TRACE 2000	9.5mm
Fisons/Carlo Erba (TMO)	
8000 series	17mm
Gow-Mac	
6890 series	11mm
All other models	9.5mm
PerkinElmer	
Sigma series	11mm
900,990	11mm
8000 series	11mm
Auto SYS	11mm
Auto SYS XL	11mm
Pye/Unicam	
All models	7mm
Shimadzu	
All models	Plug
SRI	
All models	Plug
Tracor	
540	11.5mm
550,560	9.5mm
220,222	12.5mm
Varian	
<i>Injector type:</i>	
Packed column	9.5/10mm
Split/splitless	
1078/1079	10/11mm
1177	9mm
1075/1077	11mm

### Thermolite® Septa

- Usable to 340°C inlet temperatures.
- Each batch tested on FIDs, ECDs, and MSDs to ensure lowest bleed.
- Excellent puncturability.
- Preconditioned and ready to use.
- Do not adhere to hot metal surfaces.
- Packaged in non-contaminating glass jars.



Septum Diameter	25-pk.	50-pk.	100-pk.
5mm (3/16")	20351	20352	20353
6mm (1/4")	20355	20356	20357
7mm	20381	20382	20383
8mm	20370	20371	—
9mm	20354	20358	20362
9.5mm (3/8")	20359	20360	20361
10mm	20378	20379	20380
11mm (7/16")	20363	20364	20365
11.5mm	22385	22386	22387
12.5mm (1/2")	20367	20368	20369
17mm	20384	20385	20386
Shimadzu Plug	20372	20373	20374

### InfraRed™ Septa

- Usable to 325°C inlet temperatures.
- Preconditioned and ready to use.
- Excellent puncturability.
- Do not adhere to hot metal surfaces.
- Low bleed.
- Packaged in non-contaminating glass jars.



Septum Diameter	25-pk.	50-pk.	100-pk.
9mm	21417	21418	21419
9.5mm (3/8")	21421	21422	21423
10mm	21424	21425	21426
11mm (7/16")	21427	21428	21429
11.5mm	21430	21431	21432
12.5mm (1/2")	21433	21434	21435
17mm	21436	21437	21438
Shimadzu Plug	21439	21440	21441

### IceBlue™ Septa

- Usable to 250°C inlet temperatures.
- General-purpose septa.
- Excellent puncturability.
- Preconditioned and ready to use.
- Do not adhere to hot metal surfaces.
- Packaged in non-contaminating glass jars.
- Ideal for SPME.



Septum Diameter	50-pk.	100-pk.
9mm	22381	22382
9.5mm (3/8")	22388	22389
10mm	22390	22391
11mm (7/16")	22392	22393
11.5mm	22383	22384
12.5mm (1/2")	22394	22395
17mm	22396	22397
Shimadzu plug	22398	22399

## Siltek™ Press-Tight® Connectors

- Siltek™ deactivation for inert pathways to maintain sample integrity.
- Ideal for connecting guard columns to analytical columns.
- Angled Press-Tight® connector designed at an angle approximating the curvature of a capillary column to reduce strain on column-end connections.
- Fits 0.18, 0.25, 0.32, & 0.53mm ID columns.

### Siltek™ Press-Tight™ Connectors

Press-Tight® Connector	ea.	3-pk.	5-pk.	25-pk.	100-pk.
Universal Press-Tight® Connector	—	—	20480	20449	20481
Universal Angled Press-Tight® Connector	—	—	20482	20483	20484
Universal “Y” Press-Tight® Connector	20485	20486	—	—	—
Universal Angled “Y” Press-Tight® Connector	20487	20469	—	—	—

## Universal Angled Press-Tight® Connectors

- Designed at an angle approximating the curvature of a capillary column.
- Reduces strain on column-end connections.
- Ideal for connecting guard columns to analytical columns.
- Seals all common sizes of fused silica tubing (0.18 to 0.53mm ID, outside diameters from 0.3 to 0.75mm).
- Made from inert fused silica.

Description	qty.	cat.#
Universal Angled Press-Tight® Connectors	5-pk.	20446
Universal Angled Press-Tight® Connectors	25-pk.	20447
Universal Angled Press-Tight® Connectors	100-pk.	20448

## Universal Press-Tight® Connectors

- Connect guard columns to analytical columns.
- Repair broken columns.
- Connect column outlets to transfer lines.

Description	qty.	cat.#
Universal Press-Tight® Connectors	5-pk.	20400
Universal Press-Tight® Connectors	25-pk.	20401
Universal Press-Tight® Connectors	100-pk.	20402

## Deactivated, Universal Press-Tight® Connectors

- High-temperature silanization for excellent inertness.
- Ideal for trace analysis of active compounds.
- Ideal for analysis of pesticides, semivolatile pollutants, or clinical/forensic samples.

Description	qty.	cat.#
Deactivated, Universal Press-Tight® Connectors	5-pk.	20429
Deactivated, Universal Press-Tight® Connectors	25-pk.	20430
Deactivated, Universal Press-Tight® Connectors	100-pk.	20431

## Universal “Y” Press-Tight® Connectors

- Split sample flow onto two columns.
- Split a single column flow into two detectors—perform confirmational analysis with a single injection.
- Fit 0.18, 0.25, 0.32, & 0.53mm ID columns.



Description	qty.	cat.#
Universal “Y” Press-Tight® Connector	ea.	20405
Universal “Y” Press-Tight® Connectors	3-pk.	20406



*Siltek™—the most inert deactivation available!*



## Polyimide Resin

- Permanently connects a Press-Tight® connector to a fused silica column.
- 350°C maximum operating temperature.



Description	qty.	cat.#
Polyimide Resin	5 grams	20445

Use for fused silica-to-fused silica or fused silica-to-metal connections!



Ideal for MXT® stainless steel to fused silica capillary connections!

### MXT®-Union Connector Kits—For Fused Silica Columns

- Low-dead-volume, leak-free connection.
- Reusable.
- Silcosteel® treatment ensures maximum inertness.
- Ideal for connecting guard columns and transfer lines.
- Use to oven temperatures of 350°C.
- Available in union and “Y” configurations.

Previously, easy-to-use MXT® connectors could only be used with metal tubing. Now MXT® connectors can be used with fused silica capillary columns, because of a Valcon polyimide 1/32-inch one-piece fused silica adaptor. This unique graphite-reinforced composite allows capillary columns to slide into and be locked in place simply by loosening and tightening the MXT® union 1/32-inch fitting.

### MXT®-Union Connector Kits—For Fused Silica Columns

Each kit contains the MXT® union, two 1/32-inch nuts and two one-piece fused silica adaptors.

Description	qty.	cat.#
For 0.25mm ID Fused Silica Columns	kit	21386
For 0.32mm ID Fused Silica Columns	kit	21385
For 0.53mm ID Fused Silica Columns	kit	21384

### MXT® “Y”-Union Connector Kits—For Fused Silica Columns

Each kit contains the MXT® union, three 1/32" nuts and three one-piece fused silica adaptors.

Description	qty.	cat.#
For 0.25mm ID Fused Silica Columns	kit	21389
For 0.32mm ID Fused Silica Columns	kit	21388
For 0.53mm ID Fused Silica Columns	kit	21387

### 1/32-Inch Replacement Nut

Description	qty.	cat.#
1/32" Replacement Nut	5-pk.	20389

### Valco® Connectors—One-Piece Fused Silica Adaptor Ferrule

We recommend a one-piece adaptor ferrule for use in fittings where the ferrule will not be removed. Connections are made and disconnected by loosening the fitting nut and sliding the tube out. Fused silica adaptor ferrules are available in Valcon polyimide for use up to 350°C. Valcon polyimide is a unique graphite-reinforced composite, specially prepared to maximize mechanical stability at high temperatures. The determining factor in adaptor ferrule size selection is the fused silica tubing outer diameter (OD).

### 1/32-Inch Adaptor Ferrule

Tubing OD	Tubing ID	Valco® #	qty.	Valcon Polyimide cat.#
<0.25–0.4mm	0.25mm	FS.4-5	5-pk.	20137
0.4–0.5mm	0.32mm	FS.5-5	5-pk.	20140
0.5–0.8mm	0.53mm	FS.5V-5	5-pk.	20141
1/32" Replacement Nut			5-pk.	20389

### Gerstel GRAPHPACK® 3D/2 Connectors

GRAPHPACK® technology provides a complete system that quickly and reliably makes leak-free, low-dead-volume connections. The central component is a metal-jacketed graphite ferrule—the ideal seal for GC applications. GRAPHPACK® ferrules eliminate all the disadvantages and shortcomings associated with previous sealing systems.

Description	qty.	cat.#
GRAPHPACK® 3D/2 Connector** (0.25mm to 0.32mm ID)	ea.	20272
GRAPHPACK® 3D/2 Connector** (0.45mm to 0.7mm ID)	ea.	20273

\*\*Use only with GRAPHPACK® 3D/2 ferrules.

### GRAPHPACK® 3D/2 Ferrules

Ferrule ID	Fits Column ID	qty.	cat.#
0.4mm	0.25mm	10-pk.	20271
0.5mm	0.32mm	10-pk.	20270
0.8mm	0.45/0.53mm	10-pk.	20274

## Intermediate-Polarity Deactivated Guard Columns & Transfer Lines

- Useful for a wide range of applications.
- Compatible with most common solvents.

### Fused Silica Guard Columns/Transfer Lines

Nominal ID	Nominal OD	1-Meter	5-Meter	5-Meter/6-pk.
0.025mm*	0.363 ± 0.012mm	10097		
0.05mm	0.363 ± 0.012mm	10098	10040	10040-600
0.075mm*	0.363 ± 0.012mm	10099		
0.10mm	0.363 ± 0.012mm	10100	10041	
0.15mm	0.363 ± 0.012mm	10101	10042	
0.18mm	0.37 ± 0.04mm	10102	10046	
0.25mm	0.37 ± 0.04mm		10043	10043-600
0.28mm	0.37 ± 0.04mm		10003	10003-600
0.32mm	0.45 ± 0.04mm		10044	10044-600
0.45mm	0.69 ± 0.04mm		10005	10005-600
0.53mm	0.69 ± 0.05mm		10045	10045-600

Nominal ID	Nominal OD	10-Meter	10-Meter/6-pk.	30-Meter**	60-Meter**†
0.25mm	0.37 ± 0.04mm	10049	10049-600	10012	10013
0.32mm	0.45 ± 0.04mm	10048	10048-600	10022	10023
0.53mm	0.69 ± 0.05mm	10047		10032	10033

### MXT® Guard Columns/Transfer Lines

Nominal ID	Nominal OD	5-Meter	5-Meter/6-pk.	10-Meter
0.28mm	0.53 ± 0.025mm	70044	70044-600	70046
0.53mm	0.74 ± 0.025mm	70045	70045-600	70047

## Siltek™-Deactivated Guard Columns

- Revolutionary deactivation process lowers analyte breakdown to less than 1%.
- Minimizes bleed.
- Ideal for chlorinated pesticide analysis.
- Analyze tough samples quickly and accurately.
- Maximum temperature of 380°C.

### Siltek™-Deactivated Guard Columns

Nominal ID	Nominal OD	5-Meter	10-Meter
0.25mm	0.37 ± 0.04mm	10026	10036
0.32mm	0.45 ± 0.04mm	10027	10037
0.53mm	0.69 ± 0.05mm	10028	10038

## Let Restek Make the Connection for You!

Restek will connect a Siltek™ guard column to any analytical column using a universal Siltek™ Press-Tight® connector and polyimide sealing resin. To order a preconnected guard column, add the three-digit suffix from the chart below to any analytical column catalog number when ordering.

### 5m Siltek™ Guard Column/Transfer Line

ID	cat. # suffix
0.25mm	-364
0.32mm	-365
0.53mm	-366

### Example:

A 5m, 0.32mm ID Siltek™ guard column connected to a 30m, 0.32mm ID, 1.0µm Rtx®-5 column is cat.# 10254-365.

**Restek Trademarks:** Siltek, Press-Tight, MXT, CarboFrit, Rtx, Uniliner, Silcosteel, Stx, Leak Detective, Stabilwax, Cyclo splitter, mini-Lam, Precision, InfraRed, IceBlue, Plus 1.

**Other Trademarks:** Valco (Valco Instruments Co., Inc.), GRAPHPACK (Gerstel GmbH), Carbowax (Union Carbide Corp.), TRACE (ThermoQuest Corp.), Velcro (Velcro Industries BV), Scotty (Scott Specialty Gases, Inc.), Viton & VESPEL (E.I du Pont de Nemours & Co., Inc.).

\*Not tested with the Grob test mix because of a high pressure drop.

\*\*30- and 60-meter lengths are banded in 5-meter sections.

†Recommendation: Cut 60m guard columns into shorter lengths. Using full length may cause peak distortion.

# Reach for Restek

## Plus 1 Restek's Customer Commitment

Plus 1™ Service means we will surpass your expectations every time you contact us! You'll get Plus 1™ service when you ask our experienced Technical Service team to help solve a difficult analytical problem. Our efficient Customer Service Team will provide Plus 1™ service even when you place a late-day order. Keep reaching for Restek products and service, and we will provide you with Plus 1™ quality and attention.



### **Orders & Customer Service** (in the U.S.)

**PHONE:**  
800-356-1688 (ext. 3) or  
814-353-1300 (ext. 3)

**FAX:**  
814-353-1309

**Restek Corporation**  
110 Benner Circle  
Bellefonte, PA 16823

*Monday–Friday, 8:00 a.m.–6:00 p.m. EST*

[www.restekcorp.com](http://www.restekcorp.com)

### **For customer and technical service outside the U.S....**

please contact your local Restek International location or distributor.

**Germany:** Schaberweg 23, 61348 Bad Homburg • phone: 49 06172 2797 0 • fax: 49 06172 2797 77

**France:** 1, rue Montespan, 91024 Evry • phone: 01 60 78 32 10 • fax: 01 60 78 70 90

**Ireland:** 8 Baronscourt Lane, Belfast, BT8 8RR • phone: 44 28 9081 4576 • fax: 44 28 9081 4576

**Thames Restek UK Ltd.:** Units 8-16 Ministry Wharf, Wycombe Road, Saunderton, Buckinghamshire, HP14 4HW  
phone: 01494 563377 • fax: 01494 564990



©Copyright 2002, Restek Corporation

For permission to reproduce any portion of this technical guide, please contact Restek's publications/graphics department by phone (ext. 2128) or fax (814) 353-9278.

Lit. Cat. #59880A